

DOCTORAL DISSERTATION

NGUYEN LE PHUONG LIEN

Budapest
2017



SZENT ISTVÁN UNIVERSITY

Department of Postharvest Science and Sensory Evaluation

EXTENDING THE STORABILITY OF MELON

NGUYEN LE PHUONG LIEN

Budapest

2017

PhD School/ Program

Name: Food Science Doctoral School

Field: Food Science

Head: **Gyula Vatai, DSc**
Department of Food Engineering
Faculty of Food Science
Szent István University, Budapest, Hungary

Supervisors: Géza Hitka, PhD
Department of Postharvest Science and Sensory Evaluation
Faculty of Food Science
Szent István University, Budapest, Hungary

Tamás Zsom, PhD
Department of Postharvest Science and Sensory Evaluation
Faculty of Food Science
Szent István University, Budapest, Hungary

The applicant met the requirement of the PhD regulations of the Szent István University and the thesis is accepted for the defense process.

.....
Head of Doctoral School

.....
Supervisor

.....
Supervisor

TABLE OF CONTENTS

Table of contents	3
List of abbreviations	6
1. INTRODUCTION.....	7
1.1 Problem statement.....	7
1.2 Thesis structure	9
2. LITERATURE REVIEW	11
2.1 Fruit and vegetable consumption.....	11
2.2 Fruit and vegetable production in Hungary.....	11
2.3 Melon	11
2.3.1 Melon consumption in surveyed countries.....	12
2.3.2 Watermelon and melon production in Hungary.....	14
2.3.3 Nutrition facts	15
2.3.4 Recommendation for maintaining postharvest quality of melon	16
2.3.4.1 Cantaloupe	16
2.3.4.2 Honeydew melon	16
2.3.5 Diseases during storage.....	16
2.3.5.1 Chilling injury	16
2.3.5.2 Pathogen microorganisms.....	17
2.3.5.3 Physiological disorders	18
2.3.6 Standards for grades of melon.....	18
2.3.6.1 Commission regulation (EC) No 1093/97 of 16 June 1997.....	18
2.3.6.2 U.S. Standards for Grades of Cantaloupes	18
2.4 Determining the quality of melon	19
2.4.1 Human experiences	19
2.4.2 Non-destructive measurement.....	19
2.4.2.1 Acoustics technology	19
2.4.2.2 Electrical and magnetic technology.....	20
2.4.2.3 Near infrared spectroscopy.....	20
2.4.2.4 On-line grading system.....	21
2.4.2.5 Chlorophyll fluorescence analysis.....	21
2.5 Postharvest management	21
2.5.1 Sanitizers	21
2.5.1.1 Chlorine treatment.....	22
2.5.1.2 Ozone treatment.....	23
2.5.1.3 Hot water treatment.....	24
2.5.1.4 Microbubbles application	25
2.5.2 Storage.....	26
2.5.2.1 1-Methylcyclopropene.....	26
2.5.2.2 Controlled atmosphere	28
2.5.2.3 Modified atmosphere packaging	29
2.5.2.4 Coating	29

2.5.2.5 Ethylene removal	29
2.5.2.6 Storage temperature	30
3. RESEARCH OBJECTIVE	31
3.1 Research objective	31
3.2 Research questions	31
3.3 Research scope.....	31
4. MATERIALS AND METHODS	33
4.1 Materials and methods	33
4.1.1 Melon.....	33
4.1.2 Maturity stages.....	34
4.2 Measurements.....	35
4.2.1 Ethylene production.....	35
4.2.2 CO ₂ production	36
4.2.3 Acoustic firmness	37
4.2.4 Chlorophyll fluorescence analysis	38
4.2.5 Surface color measurement	39
4.2.6 Chilling injury evaluation	39
4.2.7 Decay percentage evaluation	39
4.2.8 Disease severity evaluation.....	39
4.2.9 Mesophilic aerobes analysis	40
4.3 1-Methylcyclopropene	40
4.3.1 Application of 1-MCP gaseous form.....	41
4.3.2 Application of 1-MCP microbubbles (1-MCP MBs).....	41
4.4 Ethylene absorber.....	42
4.5 Chlorine	42
4.6 Ozone	43
4.7 Microbubbles generation system for washing treatment	43
4.7.1 Ozone microbubbles generation system	43
4.7.2 Hot water and microbubbles	44
4.7.3 Chlorinated water and microbubbles.....	45
4.8 Experimental design	45
4.8.1 Evaluating the effect of 1-MCP treatment on melon	46
4.8.1.1 Application of conventional 1-MCP at different temperatures....	46
4.8.1.2 Application of conventional 1-MCP at different days	48
4.8.1.3 Application of 1-MCP MBs	49
4.8.2 Evaluating the effect of 1-MCP, ethylene absorber and ozone.....	51
4.8.3 Evaluating the efficacy of washing treatments.....	52
4.9 Statistical analysis.....	54
5. RESULTS AND DISCUSSION	57
5.1 Effect of 1-MCP treatment on melon during storage.....	57
5.1.1 Effect of different treatment temperatures	57
5.1.2 Effect of different treatment days.....	63
5.1.3 Effect of 1-MCP microbubbles (1-MCP MBs) treatment.....	69
5.2 Effect of conventional 1-MCP, ethylene absorber and ozone treatment...74	

5.3 Effect of washing treatments on mesophilic aerobes.....	79
6. NEW SCIENTIFIC RESULTS	83
7. POSSIBLE APPLICATIONS AND SUGGESTIONS.....	85
7.1 Possible application	85
7.2 Limitations and further researches.....	85
7.2.1 Limitations	85
7.2.2 Further researches	85
8. SUMMARY	87
9. ACKNOWLEDGMENT	89
10. REFERENCES.....	91
11. APPENDIX.....	105
Appendix 1 - Pictures.....	105
Appendix 2 - Statistical results	111

LIST OF ABBREVIATIONS

1-MCP:	1-methylcyclopropene
EA:	Ethylene absorber
MBs:	Microbubbles
FV:	Fruits and vegetables

1. INTRODUCTION

1.1 Problem statement

Melon is a delicious fruit due to its attractive orange flesh, unique flavor and nutritional value (Aguayo et al., 2007). However, it has a short-term of storage and deteriorates easily resulting in losing market value including appearance, nutrition and economic (Aharoni et al., 1993; Fallik et al., 2000; Silveira et al., 2008).

1-methylcyclopropene (1-MCP) successfully controls the ripening of fruits and vegetables during storage and transport by warding off negative ethylene effects (Sisler, 2006). There have been a lot of publications about the role of 1-MCP in delaying the ripening, maintaining the texture, firmness, taste and appearance of fruits (Blankenship and Dole, 2003; Watkins, 2006).

According to those sources, the 1-MCP applications were carried out in order to prolong the postharvest life of melon. Almost primary publications were conducted the 1-MCP treatment within a day after harvest at ambient temperature (Alves et al., 2005; Du Chatenet et al., 2000; Ergun et al., 2005; Ergun et al., 2007; Gal et al., 2006; Shi et al., 2014). Rapid application of 1-MCP to melon is crucial because melon has a short shelf-life. Nevertheless, it is not really easy to carry out the 1-MCP treatment at the harvest day due to transport or occasional lack of the air tight storage room (Watkins and Nock, 2005). This is the gap in the majority of previous researches. Therefore, a question was raised: “what if the 1-MCP treatment is delayed by several days after harvest?”. So far, this is also an important question in commercial practice, particularly for storage operators who are facing the need of rapidly filling up the cold storage rooms in a short time after harvest. They usually have to wait until the storage room is fully loaded, then 1-MCP treatment will be done. Therefore, precooling followed by 1-MCP application at cold temperature is the most suitable.

Together with that issue, another question was raised as well: How long can we delay the 1-MCP application after harvest? In fact, the delay of 1-MCP application depends mainly on the possible storage facilities such as the size of storage room and the maximum day between harvest and treatment is up to cultivars (Blankenship and Dole, 2003).

Besides that, fungal infection of melon also needs attention. Melon is a ground crop, so the initial microbial populations on the melon skin are high (Bastos et al.,

2005). In addition, microorganisms easily enter the flesh through wounds, cracks and stem scar. This causes severely microbial diseases resulting in the shortening of the postharvest life of melon. Thus, it is necessary to reduce the incidence of microbial rots throughout storage.

In most general, fruit quality and safety are the rapidly growing fields of interest in academic research. New interests have emerged over the last few decades. A dozen of reports have been found in the literature including prolongation of the postharvest life of melon by 1-MCP treatment as well as sanitization of produce (Alves et al., 2005; Du Chatenet et al., 2000; Ergun et al., 2007; Fallik et al., 2000; Lima et al., 2004; Watkins, 2006; Ukuku, 2006). Besides the published researches about melon, there are still some interesting aspects in postharvest treatment needing to be explored.

In conclusion, this study is different from previous researches in the following main areas:

- Firstly, application of 1-MCP on melon at different days after harvest was tested;
- Secondly, 1-MCP microbubbles treatment as an innovative postharvest technique for the shelf-life extension of melon was tested;
- Thirdly, the combination of 1-MCP and ethylene absorber or ozone treatment was tested;
- Fourthly, comparison between traditional washing methods and microbubbles treatment in reducing microbial populations on melon skin was conducted.

1.2. Thesis structure

The next content of this thesis includes five chapters, which clarified as following:

- Part Nr.2 gives an overview about melon as well as the approaches used in preserving and determining the quality of fruits during storage, particularly focuses on melon.
- Part Nr.3 proposes the research objective.
- Part Nr.4 presents materials, experiments, and measurements. In addition, research questions will be elucidated.
- Part Nr.5 presents the empirical results of this study, and then they will be discussed in comparison with the earlier reports.
- Part Nr.6 draws up an outline of new findings.
- Part Nr. 7 proposes feasible applications, and the limitations as well as potential facets for further investigation.
- Part Nr. 8 summarizes the thesis.
- Part Nr. 9 is the acknowledgment.
- Part Nr. 10 is the references.
- Part Nr. 11 is the appendixes including pictures and statistical results.

2. LITERATURE REVIEW

2.1 Fruit and vegetable consumption

Fruits and vegetables (FV) are essential foods for human being. Consuming fruit and vegetable daily could reduce risk of depression and diseases including types of cancer or cardiovascular (Bonany et al., 2013). In addition, evolving well-being and happiness after increasing FV consumption was also observed (Mujcic et al., 2016). The minimum daily intake of vegetables and fruits is 400 g per day per person that is recommended by FAO/WHO (WHO, 2003). Although adults are aware of the benefit of FV for health, but few people adopt current guidelines (McSpadden et al., 2016). FV consumption has also been increasing because of healthy diet recommendation in recent years (Callejón et al., 2015), however, the survey data showed that more than 75 % of the world population has consumed FV less than the recommended daily intake (Bonany et al., 2014; Hall et al., 2009).

Possible barriers affecting the insufficient consumption of fruits and vegetables might be a poor and inconsistent quality, insufficient FV safety, prices or the lack of availability and convenience (Bonany et al., 2013). Thus, ensuring fruit quality during transport and storage in order to meet consumers' demand is necessary. There were many approaches limiting the negative changes in preserving fruits and vegetables (Terry et al., 2007; Zagory, 1995) would be discussed in next part.

2.2 Fruit and vegetable production in Hungary

In six years from 2009 to 2014, fruits and vegetables production in Hungary went up by 25.5 %, which has been accompanied by a 3.5 % rise in area cultivation (FruitVeB, 2014). Besides, average export and import values of FV including fresh, frozen, dried and preserved product in this period also rose by 17.73 % and 16.78 %, respectively. These results showed that FV consumption in Hungary has been rising.

2.3 Melon

Melon is a major horticultural crop in the world. In 2012, its production was more than 27 million tons with the 9th ranking of world vegetables production (FAO, 2014). Melons originated from Africa (Kirkbride, 1993), nowadays, melons were consumed widely holding a large market in Europe, the United States and Japan (FAO, 2013).

The common melon varieties in the US are ‘Cantaloupe’ (*Cucumis melo* L. var. *reticulatus* Naud) and ‘Honeydew’ (*C. melo* L. var. *inodorus* Naud) with the production of 768930 tons, 156130 tons in 2012, respectively (USDA, 2013). ‘Galia’, ‘Cantaloupe’, ‘Amarillo’ and ‘Piel de Sapo’ are the most common types in Europe, particularly in Spain (Aguayo et al., 2007). Spain is ranked on the 7th position about the world melon production (FAO, 2013).

Muskmelon (*Cucumis melo* L. var. *reticulatus*) has orange flesh, white or brown net on the fruit surface, and a strong musky aroma. Melons are climacteric fruits having a relatively short shelf-life, thus this produce is used primarily for local, fresh-market consumption (Jeong et al., 2008; Seymour et al., 1993).

2.3.1 Melon consumption in surveyed countries

There were four surveyed countries including France, Spain, Germany and the Netherlands. Generally, melon is one of the most consumed fruits in France and Spain ranked 5th after apple, orange, pear and banana. Meanwhile, melon was at the average portion among consumed fruits in Germany, and not popular in the Netherlands (Table 1) (Pérez-Jiménez and Saura-Calixto, 2015).

Table 1. Consumption of fruits and vegetables in four European countries (data referred to edible part) (Pérez-Jiménez and Saura-Calixto, 2015).

France		Germany		The Netherlands		Spain	
Sample	Con. (%)	Sample	Con. (%)	Sample	Con. (%)	Sample	Con. (%)
Fruit							
Apple	31.3	Apple	30.4	Apple	37.4	Orange	20.7
Orange	9.1	Banana	11.6	Banana	14.9	Apple	10.5
Pear	7.1	Orange	10.9	Orange	14.1	Pear	7.5
Banana	6.1	Mandarin	6.8	Mandarin	8.8	Banana	8.1
Melon	6.0	Grape	7.4	Pear	7.8	Melon	7.4
Grape	5.5	Peach	5.9	Total	83.0	Mandarin	6.3
Mandarin	5.3	Pear	4.8			Peach	6.1
Peach	4.2	Melon	3.2			Watermelon	6.2
Watermelon	0.7	Total	81.0			Grape	2.9
Total	75.3					Total	76.0
Vegetables							
Tomato	17.8	Tomato	37.5	Brussels sprouts	18.2	Tomato	27.5
Carrot	15.0	Carrot	9.7	White cabbage	12.0	Onion	13.0
Lettuce	12.1	Courgette	9.0	Green beans	11.3	Lettuce	5.4
Green beans	7.8	Onion	9.1	Tomato	10.7	Pepper	8.1
Chicory	7.4	Green beans	6.1	Chicory	7.9	Cucumber	4.2
Courgette	6.2	White cabbage	2.9	Carrot	6.1	White cabbage	2.8
Onion	5.7	Broccoli	2.7	Spinach/chard	5.3	Green beans	4.4
White cabbage	3.6	Lettuce	1.4	Red beetroot	4.2	Spinach/chard	3.3
Broccoli	1.8	Asparagus	1.0	Lettuce	4.2	Carrot	3.4
Pepper	1.6	Spinach/chard	0.2	Total	80.0	Asparagus	2.5
Asparagus	1.2	Total	79.5			Total	74.4
Total	80.2						

Con.: consumption

2.3.2 Watermelon and melon production in Hungary

As shown in table 2, the area covering watermelon and melon crop decreased, however, their productions leveled up significantly (Table 3) (FruitVeB, 2014)

Table 2. Area cultivation of watermelon and melon (ha) in Hungary from 2009 to 2014 (FruitVeB, 2014)

Year\Produce	2009	2010	2011	2012	2013	2014
Watermelon	6500	6577	5250	4900	5650	6000
Melon	750	700	532	450	560	515

Table 3. Production of watermelon and melon (1000 tons)in Hungary from 2009 to 2014 (FruitVeB, 2014)

Year\Produce	2009	2010	2011	2012	2013	2014
Watermelon	174.0	110.6	178.0	192.0	218.0	220.0
Melon	12.1	7.9	12.1	12.0	16.8	17.0

From 2011 to 2013, the export production of watermelon increased and had a slight decline in 2014 (Table 4), whereas the import production of watermelon generally decreased (Table 5). Melon production declined sharply in case of export as well as import in those periods (Tables 4, 5) (FruitVeB, 2014).

Table 4. Export production of watermelon and melon (tons) in Hungary (FruitVeB, 2014)

Year\Produce	2011	2012	2013	2014
Watermelon	45788	54014	68122	64418
Melon	107	1433	60	18

Table 5. Import production of watermelon and melon (tons) in Hungary (FruitVeB, 2014)

Year\Produce	2011	2012	2013	2014
Watermelon	7023	5245	8537	5814
Melon	1341	830	953	911

2.3.3 Nutrition facts

Melon has a low level of sodium, iron and calcium, but it is a rich source of potassium, vitamin C, pro-vitamin compared to others fruits (Table 6).

Table 6. Nutrition facts (U.S. Food and Drug Administration, January, 2008)
Raw, edible weight portion. Percent Daily Values (% DV) are based on a 2000 calorie diet.

Fruits Serving size(gram weight/ounce weight)	Sodium (mg) % DV	Potassium (mg) % DV	Vitamin A % DV	Vitamin C % DV	Calcium % DV	Iron % DV
Apple 1 large (242g/8oz)	0 0	260 7	2	8	2	2
Avocado 1/5 medium (30g/1.1oz)	0 0	140 4	0	4	0	2
Banana 1 medium (126g/4.5oz)	0 0	450 13	2	15	0	2
Cantaloupe ¼ medium (134g/4.8oz)	20 1	240 7	120	80	2	2
Grapefruit ½ medium (154g/5.5oz)	0 0	160 5	35	100	4	0
Grapes ¾ cup (126g/4.5oz)	15 1	240 7	0	2	2	0
Honeydew melon 1/10 medium melons (134g/4.8oz)	30 1	210 1	2	45	2	2
Kiwifruit 2 medium (148g/5.3oz)	0 0	450 3	2	240	4	2
Lemon 1 medium (58g/2.1oz)	0 0	75 2	0	40	2	0
Lime 1 medium (67g/2.4oz)	0 0	75 2	0	35	0	0
Nectarine 1 medium (140g/5.0oz)	0 0	250 7	8	15	0	2
Orange 1 medium (154g/5.5oz)	0 0	250 7	2	130	6	0
Peach 1 medium (147g/5.3oz)	0 0	230 7	6	15	0	2
Pear 1 medium (166g/5.9oz)	0 0	190 5	0	10	2	0
Plum 1 medium (151g/5.4oz)	0 0	230 7	8	10	0	2
Strawberries 1medium (147g/5.3oz)	0 0	170 5	0	160	2	2
Sweet Cherries 1cup (140g/5.0oz)	0 0	350 10	2	15	2	2
Tangerine 1medium (109g/3.9oz)	0 0	160 5	6	45	4	0

2.3.4 Recommendation for maintaining postharvest quality of melon

2.3.4.1 Cantaloupe (source: Postharvest Technology Center, UC Davis, USA)

Temperature: 2.2 – 5 °C and RH: 90-95 %.

When storage temperatures below 2.2 °C, chilling injury occurs after several days. Chilling injury are symptoms including pitting or sunken areas, failure to ripen and off-flavors.

2.3.4.2 Honeydew melon (source: Postharvest Technology Center, UC Davis, USA)

Temperature: 7 – 10 °C and RH: 85-90%.

When storage temperatures below 7 °C, there are some symptoms of chilling injury comprising pitting, discoloration, failure to ripen and off-flavors.

2.3.5 Diseases during storage

2.3.5.1 Chilling injury (CI)

CI of melons begins by the development of rind pitting. Then, there are many brown spots or discoloration on the surface of fruit during storage and post-storage marketing (Figs. 1, 2). The internal quality of fruits might not be affected, but the external quality of melon suffers serious problem. Storage temperature at 4-6 °C increases CI of ‘Galia’ melon rind, however, CI does not occur at higher temperature 8-10 °C (Fogelman et al., 2011).

CI symptoms of Hami melon were brownish pitting and water-soaked areas on surface (Yang et al., 2003).



Figure 1. Chilling injury



Figure 2. Surface discoloration

(Source: Postharvest Technology Center, UC Davis, USA)

2.3.5.2 Pathogen microorganisms

Microbial pathogen was a phenomenon of fungal growth on the stem end and rind of melon (Yang et al., 2003). Main fungi causing decay on ‘Galia’ melon are *Alternaria alternate* and *Fusarium spp* (Aharoni et al., 1993). Fungi caused spoilage Hami melon such as *Fusarium spp.*, *Alternaria spp.*, *Rhizopus spp.*, *Mucor mucedo* and *Trichothecium roseum*. Minor pathogens were related to *Cladosporium spp.*, *Penicillium spp.* and *Geotrichum candidum*. Fusarium rot had the highest incidence occurring at the stem-end, cracks and nets on the rind. Alternaria rot occurred in nets of the rind and CI area. Rhizopus and Mucor rots were mainly associated with mechanical damage of melon surface. Trichothecium rots were found at stem-end, flower-end and on melon surface. At room temperature, Fusarium, Rhizopus and Trichothecium rots were more serious, while lower temperature was favorable for Fusarium, Alternaria and Mucor rots (Yang et al., 2003). Authors found that fungi causing decay of Hami melon were similar to other types of melon in previous studies (Ceponis et al., 1986; Yang et al., 2003). Some of the most frequently seen problems with microbial origin are to be seen in Figs. 3-8.

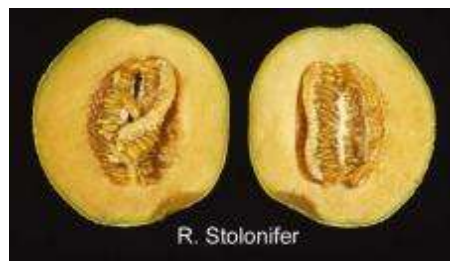

Figure 3. Rhizopus rot (Cantaloupe)



Figure 4. Sour rot (Cantaloupe)



Figure 5. *Botryodiplodia* decay



Figure 6. *Fusarium* decay (honeydew)



Figure 7. *Penicillium* decay



Figure 8. Severe symptoms of brown (honeydew)

(Source: Postharvest Technology Center, UC Davis, USA)

2.3.5.3 Physiological disorders

There are several common disorders: solar injury, surface cracking (Fig. 9), and surface discoloration (Fig. 10). Solar injury causes patchy ground color or ‘bronzing’ and net discoloration. Severely injured melon tissue becomes sunken or wrinkled.



Figure 9. Surface cracking



Figure 10. Surface discoloration (honeydew)

2.3.6 Standards for grades of melon

2.3.6.1 Commission regulation (EC) No 1093/97 of 16 June 1997

This standard applies for fresh produce including varieties grown from *Cucumis melo* L.

The regulation includes: Provisions concerning quality (Minimum requirements, Classification), Provisions concerning sizing, Provisions concerning tolerances (quality and size), Provisions concerning presentation (Uniformity and packaging), Provisions concerning marking (Identification, Nature of produce, Origin of produce, Commercial specifications, Official control mark).

2.3.6.2 U.S. Standards for Grades of Cantaloups (USDA, 2006)

U.S. Grades for cantaloups include U.S. Fancy; U.S. No. 1; U.S. Commercial; and U.S. No. 2.

Following U.S. grade standards, melons must have sufficient maturity to insure completion of ripening; sufficient firmness (not soft or wilted); shape and netting

characteristic for their type; a stem scar not wet and slippery (wet slip); no sun scald (solar injury); flesh and rind free of decay by fungi or bacteria; and absence of damage. Damage includes liquid in the seed cavity, hail injury, surface mold, aphid or other insects, scars, cracks, ground spot rind disorders, bruises and mechanical damage.

2.4 Determining the quality of melon

2.4.1 Human experiences

Nowadays, the higher standard of living is, the more quality of food is required. Therefore, evaluation the quality of food plays an important role. Many years ago, internal characteristics of fruits and vegetables such as soluble solids content (SSC), firmness, internal defect, and maturity were assessed by human experiences. For example, the maturity of watermelons was determined by the changes of surface color, aroma, tendril withering or a thumping test (Sun et al., 2010).

For melon, the abscission zone is useful sign to determine the maturity of this fruit (Bett-Garber et al., 2003). Cantaloupe is only ready to harvest around that developmental or ripening stage when the advancement of abscission layer occurs. Earlier harvested melons than the advancement of the abscission layer, will not possess the required flavor, taste and aroma characteristic to the fully mature fruit still on the stem (Beaulieu and Grimm, 2001). These judgments are subjective, there may be differences between two people or two times. Thus, the evaluation process could not obtain high accuracy and also takes much time for sorting and grading.

2.4.2 Non-destructive measurement

Recently, non-destructive measurement techniques such as acoustic technology, impact technology, electrical and magnetic technology, X-ray and computed tomography, chlorophyll fluorescence, and near infrared (NIR) spectroscopy have been used widely in food industry (Sun et al., 2010). These methods are objective, more rapid and accurate compared to human judgments.

2.4.2.1 Acoustics technology

Acoustic technology could replace traditional method and has become a rapid test for watermelon sorting and grading (Mizrach et al., 1996). Internal properties of fruits and vegetables were evaluated by acoustic properties (Schotte et al., 1999; Zsom-Muha and Felfödi, 2007).

Each agricultural product has its own acoustic characteristics due to different internal tissue structures. Several acoustic characteristics are used for evaluation: attenuation coefficient, transmitting velocity, acoustic impedance, and frequency, which were obtained from the reflected or transmitted acoustic wave (Sun et al., 2010). Firmness, dry weight and total soluble solids content of melon were determined by acoustic properties (Mizrach et al., 1994). There was a study about the relationship between the transmission velocity and firmness of muskmelons. The results showed that the transmission velocity became lower when muskmelons ripened (Sugiyama et al., 1994). A portable firmness tester measuring physiological changes of fruit during ripening was also made (Sugiyama et al., 1998). This device recorded the transmission velocity of an impulse wave that was induced by the impact of a plunger. Later on, a digital firmness tester was used to determine the appropriate time to harvest melon (Al-Haq et al., 2004).

Recently, AWETA (AFS, Nootdorp, The Netherlands) as a commercial desktop unit has been applied widely to determine the acoustic and impact firmness of fruits. Its main parts were an electromagnet-driven probe exciting the fruits, a small microphone recording the vibration of fruit and a weight cell measuring the samples (De Ketelaere et al., 2006).

2.4.2.2 Electrical and magnetic technology

Other non-destructive measurement used to evaluate the internal quality attributes of fresh fruits and vegetables such as density, freshness and maturity is the electrical and magnetic technology (Sun et al., 2010). There were many studies assessing the internal qualities of melon. Nelson et al. (2006) found that there was a correlation between soluble solid content (SSC) and dielectric properties of honeydew melons in a frequency range of 10 MHz–1.8 GHz. These authors also assessed SSC of watermelon by using dielectric properties in a frequency range of 10 MHz–1.8 GHz (Nelson et al., 2007). Besides, the internal qualities of watermelon including degree of hollowness, and maturity were also determined (Sun et al., 2010).

Magnetic resonance imaging (MRI) was found to be efficient in detecting internal defects of horticultural commodities. MRI systems were used to assess the internal qualities of tomatoes and pears (Hernández-Sánchez et al., 2007; Milczarek et al., 2009), however, the disadvantage of this technique was the expensive instrument.

2.4.2.3 Near infrared (NIR) spectroscopy

NIR spectroscopy technique is a modern analysis method, applied in many areas; however, the instruments are very expensive (Sun et al., 2010). The advantages of this method are non-destructive and non-invasive detection, no sample preparation and fast measurement. NIR spectroscopy is efficient to evaluate SSC, firmness, and internal defects of watermelons and melons (Liu and Ying et al., 2005).

2.4.2.4 On-line grading system

An automatic system for sorting low density watermelons with cavities was applied. It was effective in classifying watermelons into six levels by the degree of hollowness (immature, no cavity, small cavity, medium cavity, large cavity, and off-specification large cavity) (Fan et al., 2015; Kato, 1997). Many watermelon sorting machines were developed, Noh and Choi (2006) invented a new watermelons sorting system for watermelon grading in Korea. A sorting system for ripeness and cavity determination based on acoustic properties was also devised (Sun et al., 2010).

2.4.2.5 Chlorophyll fluorescence analysis

Chlorophyll fluorescence measurement is a rapid, non-invasive technique which has been utilized in examining the photosynthetic activity of plants. Chlorophyll content and its photosynthetic performance often correlated to maturity of plant tissues and injury symptoms (Abbott, 1999). For example, chilling injury symptom of crops has been detected by chlorophyll fluorescence, because chilling stress causes the decline in F_v/F_m (Baker and Rosenqvist, 2004). Recently, chlorophyll fluorescence imaging was also applied to estimate the postharvest damage before visual symptoms appear (Gorbe and Calatayud, 2012). Chlorophyll fluorescence imaging was applied to investigate the quality of apples, pears, grapes after postharvest (Gorbe and Calatayud, 2012). Fluorescence imaging could detect different areas of lemon skin: healthy, damaged or infected peels basing on different fluorescence signatures during postharvest ripening (Nedbal et al., 2000).

2.5 Postharvest management

Nowadays, fruits and vegetables market is highly competitive, thus maintaining quality of FV including nutrition, microbial safety and specific characteristics during storage is necessary. There have been many approaches limiting the negative changes after harvest (Terry et al., 2007; Zagory, 1995) would be discussed in this part.

2.5.1 Sanitizers

Soil, irrigation water, and process water were potential sources of microbial contamination. If washing did not sufficiently clean fruits prior to use, postharvest-processed fruits often had greater microbial counts than field-fresh fruits (Gagliardi et al., 2003). Thus, FV consumption could contribute to cause high rate of foodborne illnesses (Callejón et al., 2015; Nyarko et al., 2016), particularly FV are often consumed raw. Therefore, washing is an important process to reduce microbial contamination on skin or in fresh-cut procedure (Silveira et al., 2008).

Cantaloupe rind and flesh are easily infected by *Salmonella spp.* and *Escherichia coli* O157:H7 (Golden et al., 1993). Sanitizing agents including chlorine, ozone, H₂O₂, peracetic acid, commercial detergents have been widely used to reduce microbial populations on melon skin (Saper et al., 2001; Simmons et al., 1996).

2.5.1.1 Chlorine treatment

Chlorine is one of the most effective and common disinfection agents in food industry, particularly for fresh-cut salad and vegetables. However, the limitation of chlorine relates to environmental and health risk due to formation of carcinogenic by-product trihalomethane (Gil et al., 2009).

There were many reports indicating the effectiveness of chlorine in disinfecting melon. Chlorine was often used at concentration of 150-200 ppm to reduce microbial loads on skin surface of melon before storage or fresh-cut processing (Botondi et al., 2016; Sapers et al., 2001; Selma et al., 2008; Silveira et al., 2008; Silveira et al., 2010). Besides, the combination of chlorine and surfactant could enhance the efficacy of chlorine in declining the microorganism populations on melon rind surface (Bastos et al., 2005). The results showed that the combination of 0.1 % w/v Tween 80 and chlorinated solutions decreased significantly the population of the mesophilic aerobes, coliforms and *S. enteritidis* (Bastos et al., 2005).

Ukuku (2006) also compared the effect of sanitizing treatments on removing microorganism from cantaloupe surface. Melons were immersed in 200 ppm chlorine, 2.5 % hydrogen peroxide solutions or hot water (96 °C) for 2 min. Chlorine, hydrogen peroxide or hot water treatment successfully controlled the microbial populations on cantaloupe surface by reducing approximately 2.6 log, 2.6 log, and 4.9 log, respectively. However, the sanitized melons are easily recontaminated later on. These results were in agreement with other report (Gil et al., 2009).

2.5.1.2 Ozone treatment

Ozone being a powerful oxidizing substance has been applied to water disinfection for many purposes in Europe for a long time (Guzel-Seydim et al., 2004). Later, ozone has been granted as a sanitizing agent in food and food processing in the US (USDA, 1997).

a) Physical properties

Ozone has a pungent odor and no color at room temperature. It decomposes into oxygen quickly at room temperature, and faster in aqueous solution, particularly much more rapidly at high water temperatures (Table 7) (Guzel-Seydim et al., 2004).

Table 7. Solubility of ozone in water at different temperatures (Guzel-Seydim et al., 2004)

Temperature	Solubility (liter ozone/liter water)
0	0.640
15	0.456
27	0.270
40	0.112
60	0.000

Ozone is the second strongest oxidant, much more powerful than chlorine (Table 8). Moreover, ozone oxidations do not produce by-products harming human health compared to conventional disinfectant chlorine. Therefore, ozone is an alternative sanitizer in food industry (Ali et al., 2014).

Table 8. Oxidation potential of oxidants (Guzel-Seydim et al., 2004)

Oxidizing agent	Oxidation potential (mV)
Fluorine	3.06
Ozone	2.07
Permanganate	1.67
Chlorine dioxide	1.50
Hypochlorous acid	1.47
Chlorine gas	1.36

b) Mechanisms of antimicrobial property

Ozone oxidizing the essential components of cellular microorganism causes cell death. Ozone attacks microbial cell surface, it firstly reacts with sulfhydryl groups, peptides and proteins and then poly unsaturated fatty acid leading leakage of cellular compositions (Victorin, 1992). Ozone damages most proteins inside microbial cells, whereas chlorine selectively oxidizes internal cellular enzymes (Kim et al., 1999).

c) Ozone toxicity

Ozone is not a toxic gas at low concentrations. However, at high concentration ozone may damage human health, it causes several symptoms: headache, dizziness, cough and eye problem (Guzel-Seydim et al., 2004). The Threshold Limit Value – Short Term Exposure Limit (TLV-STEL) of gaseous ozone regulated by The United States Occupational Safety and Health Administration (US-OSHA) is 0.3 ppm. It means that individuals can be in workplace at 0.3 ppm ozone for 15 min without harm. The US-OSHA Threshold Limit Value – Time Weighed Average (TLV-TWA) is 0.1 ppm, at this concentration individuals can stay routine for a normal 8 h workday (Palou et al., 2002).

d) Use of ozone in fruit treatment

There are many applications of ozone in industry, however, food surface disinfection and equipment hygiene are mainly used in food industry due to its antimicrobial property (Guzel-Seydim et al., 2004). Ozone is commonly utilized in postharvest management of fruits and vegetables for two purposes including ethylene removal and sanitizing, particularly pre-storage disinfection or treatment during storage (Paulo et al., 2002).

Both gaseous form or aqueous solution of ozone have been used widely in sanitizing melon and the efficacy of ozone in decreasing the microbial populations was reported (Botondi et al., 2016; Selma et al., 2008; Silveira et al., 2010). Silveira et al. (2010) found that ozone could replace chlorine in melon fresh-cut preparation.

There have also been researches reporting the efficacy of ozone in extending shelf-life and reducing microorganism of fresh fruit such as table grapes (Sarig et al., 1996), fresh-cut celery (Zhang et al., 2005), sliced tomatoes (Aguayo et al., 2006), and date fruits (Habibi Najafi et al., 2009).

2.5.1.3 Hot water treatment

The efficacy of hot water treatment in declining postharvest diseases has been reported for numerous fruits and vegetables (Paull and Chen, 2000). This washing method has a lot of benefits: economic cost, non-chemical, short duration treatment and ease of monitoring. However, heat damage could be detected on treated fruit at temperature above 60 °C (Fallik, 2004). The treatment temperatures and time depends on species, cultivars, and fruit size (Fallik, 2004). There was a report indicated that ambient or warm (50 °C) water for 1 min was ineffective in reducing the microbial load

on melon rind surface (Sapers et al., 2001). In contrast, hot water rising and brushing at 59 °C for 15 s could control decay on ‘Galia’ melon during storage (Fallik et al., 2000). The similar effectiveness of hot water on melon was also reported (Fallik et al., 2000; Fan et al., 2006; Mayberry and Hartz, 1992; Ukuku, 2006).

2.5.1.4 Microbubbles application (MBs)

Recent years, microbubble technology has been an interesting topic due to its application in various fields: bioreactors, medical, and waste water treatment (Agarwal et al., 2011; Zimmerman et al., 2011). Microbubbles (MBs) are very small bubbles having diameter of 10-50 μm (Takahashi et al., 2007). MBs have drawn attention since the mid 1990s because of important characteristics such as negative surface charge and shrinkage in water (Zimmerman et al., 2011). MBs can reside in water for a long time compared to macrobubbles rising rapidly and bursting at surface. This important property makes MBs to deliver gas into a solution effectively (Fig. 11) (Zimmerman et al., 2011).

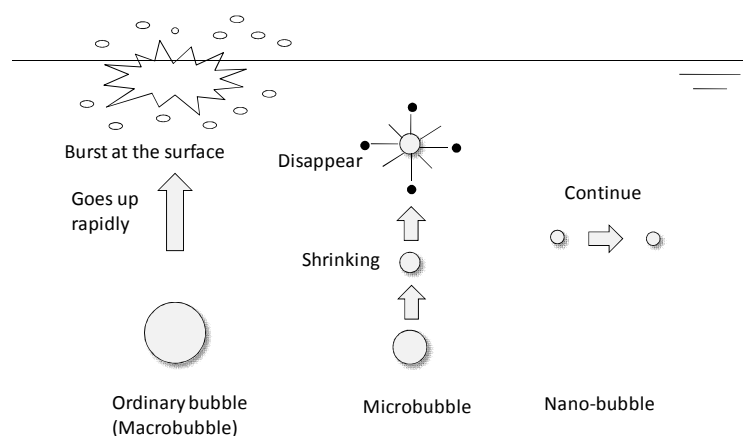

Figure11. Schematic diagram showing macro, micro and nanobubbles (Takahashi et al., 2007)

Its characteristic makes MBs useful for relevant purposes. For example, there were studies showing that MBs could dissolve and disperse gas into water efficiently and therefore stimulate lettuce root growth and agal growth (Park and Kurata, 2009; Zimmerman et al., 2011).

MBs of oxidizing gases such as oxygen and ozone have high potential in water disinfection due to generating free radicals (Agarwal et al., 2011). $\cdot\text{OH}$ radicals which are produced by MBs collapsing could improve disinfection ability (Marui, 2010; Takahashi et al., 2007). There have been many reports indicating ozone MBs have much

more efficacy in controlling microbial populations than conventional ozone treatment (Sumikura et al., 2007; Jyoti and Pandit, 2004).

2.5.2 Storage

The postharvest ripening process results in changing the biochemical compositions of FV (Abbott, 1999). Therefore, it is necessary to storage FV, because very often fruits are not consumed immediately after harvest.

Applications of 1-MCP (Ergun et al., 2005; Gal et al., 2006), controlled or modified atmosphere (Qi and Watada, 1999; Bai et al., 2001), and edible coatings (Raybaudi-Massilia et al., 2008) have been markedly effective in extending the shelf-life of melon.

2.5.2.1 1-Methylcyclopropene

1-Methylcyclopropene (1-MCP) is an ethylene action inhibitor has been used widely to prevent the ripening of fruits and vegetables (Sisler, 2006; Watkins, 2006). It is remarkable that 1-MCP treatment could extend the storage potential of a number of fruits including muskmelon (Blankenship and Dole, 2003). The internal quality of 1-MCP treated melons was better than that of control fruits (Lima et al., 2004). 1-MCP doubled the shelf-life of cantaloupe melons at ambient temperature (Alves et al., 2005). 1-MCP can be applied as a spray, gas or an aqueous solution.

1-MCP sprayable form was applied in the apple orchard for preharvest management (Elfving et al., 2007; Yuan and Carbaugh, 2007). Sprayable 1-MCP reduced fruit quality loss when delayed harvest (Yuan and Carbaugh, 2007). Moreover, sprayable 1-MCP was also as effective as postharvest 1-MCP treatment when preharvest application was closer to harvest (Elfving et al., 2007). Sprayable 1-MCP offered promising effects for growers and storage operators when delayed commercial harvest (Elfving et al., 2007). However, 1-MCP concentration was an important factor, the previous report showed that sprayable form provided only a minor benefit on apple at low concentration (Byers et al., 2005), whereas the effect of preharvest treatment increased with the increase of treatment concentration.

1-MCP gaseous form has been commonly used in research as well as practice (Hitka et al., 2014; Nguyen et al., 2016). Nevertheless, this delivery system has some requirements including: air tight storage room and long treatment time approximately 12-24 h (Sozzi and Beaudry, 2007). Sometimes, the commercial application might be

delayed, because the storage room is not fully loaded (Argenta et al., 2007). In addition, the contact between 1-MCP gas and produce surface occasionally is uneven (Golding et al., 1998; Harris et al., 2000; Pongprasert and Srilaong, 2014). Thus, 1-MCP aqueous solution has been applied to overcome the limits of gaseous form (Argenta et al., 2007). Treatment time of aqueous 1-MCP is only 4 min but treatment concentration in water was a 700-fold higher amount than that in air to achieve the similar effects (Argenta et al., 2007). Therefore, aqueous form is not economic based on the used amount due to low solubility in water of 1-MCP (Pongprasert and Srilaong, 2014). Thus, 1-MCP MBs as an innovative delivery system was investigated to increase dispersal and dissolution of 1-MCP in water. Recently, 1-MCP microbubbles method was applied on banana. The research indicated that 1-MCP microbubbles method offered a promising technique for delaying the ripening of banana and other produce as well (Pongprasert and Srilaong, 2014). The efficacy of 1-MCP depends on major factors below (Sozzi and Beaudry, 2007; Watkins, 2008):

- Genotype (variety and cultivar)
- Preharvest management
- Fruit maturity (harvest date)
- Treatment conditions
- Interaction between 1-MCP and treatment environment

Genotype

1-MCP has strong effect on climacteric fruit. The 1-MCP efficacy varying between different cultivars ranges from super to fair. The cuticle being specific for each cultivar influences the absorption of 1-MCP into fruits. The different responses of fruits results in diffusion of 1-MCP through the peel to exert its action (Sozzi and Beaudry, 2007).

Preharvest management

The quality of fruits might be effected by the past record. Past record here means environmental and manipulations such as irrigation, region, light, temperature and pruning. 1-MCP could synergistically enhance the effect of preharvest. For example, 1-MCP sun exposure pear had higher firmness than 1-MCP shaded pear. The behavior of fruits during storage had differences corresponding to various preharvest conditions (Sozzi and Beaudry, 2007; Watkins, 2008).

Fruit maturity

The efficacy of 1-MCP is low at late harvest (Hitka et al., 2014; Jia et al., 2014; Sozzi and Beaudry, 2007).

Treatment conditions

Most primary researches on 1-MCP application were conducted at ambient temperature. There have been studies reporting that 1-MCP application at cold temperature was not as effective as those carried out at warmer temperatures. Sometimes, 1-MCP did not have an effect on some crops. However, the effectiveness of 1-MCP depends not only on treatment temperature, but also on cultivar, maturity, concentration and treatment time (Watkins, 2006). There were several reports about the correlation between treatment period and temperature. DeEll et al. (2002) found that corresponding exposure duration of ‘Cortland’ apples was 6 h at 23 °C or 9 h at 3 °C. Other research also indicated that there was no difference between treatment at 20 °C and at 0.5 °C for 24 h (Watkins & Nock, 2005).

Besides, treatment concentration also plays an important role to the response of fruits. Overdosing could prevent ripening, whereas lower concentration might not achieve full efficacy. Treatment concentration depends on the sensitivity of cultivar (Blankenship and Dole, 2003; Watkins, 2006).

Interaction between 1-MCP and treatment environment

The depletion of 1-MCP by ‘non-target’ materials from fruit storage facilities has been considered (Vallejo et al., 2006). High density polyethylene (HDPE) and polypropylene (PP), polyurethane foam and fire retardant almost do not absorb 1-MCP during treatment. Plywood, cardboard, slightly-weathered oak and extensively-weathered oak strongly absorbed 16, 18, 55, and 75 % of the 1-MCP after 24 h, respectively. Moisture substances absorb 1-MCP more strongly than dry stuffs. The loss of 1-MCP to non-target materials usually occurs in controlled atmosphere rooms for apples and pears. However, it is not a problem when 1-MCP levels are near the maximum rate (Vallejo et al., 2006).

2.5.2.2 Controlled atmosphere (CA)

The main factors affecting the storage life of FV are maturity stage, temperature and relative humidity during transportation and storage. Besides, atmosphere (O₂, CO₂ and C₂H₄) surrounding the commodity also contributes significantly in prolonging the

postharvest life of fruits (Kader et al., 1989). Increasing concentration of CO₂ could control mold, reduce ethylene effects, but could cause anaerobic respiration in some commodities. Low levels of O₂ reduces respiration and ethylene synthesis, however, it also stimulates anaerobic respiration causing off-flavors due to the accumulation of ethanol and acetaldehyde (Saltveit, 2003). Therefore, choosing suitable O₂ and CO₂ levels - so that commodities can tolerate without injury and maintain quality during storage - is important (Brecht et al., 2001). For example, mature-green fruits cannot tolerate higher levels of CO₂ as ripe fruits. Each commodity has a different threshold of low O₂ and high CO₂ concentration (Kader et al., 1989).

The effect of controlled atmosphere (CA) on 'Galia' melon during storage was investigated (Aharoni et al., 1993). The results indicated that CA (10% CO₂ and 10% O₂) could decrease the softening of melon during 14 days of storage at 6 °C plus 6 days at 20 °C compared to control. In addition, the external appearance of fruits treated in CA was significantly better than control. CA had potential to slow aging and deterioration of melon.

2.5.2.3 Modified atmosphere packaging (MAP)

Modified atmosphere packaging (MAP) has been used to extend the shelf-life of fresh-cut melon (Bai et al., 2001; Oms-Oliu et al., 2008; O'Connor-Shaw et al., 1996). Gas mixtures consisting of low O₂ concentrations (2.5 kPa) and high CO₂ levels (7 kPa) have been recommended for fresh-cut melons (Oms-Oliu et al., 2008).

2.5.2.4 Coating

Edible coatings have been used to decrease moisture loss, prevent physical damage and enhance product appearance (Cong et al., 2007). The combination of edible coatings and antimicrobial substances successfully controlled microbial spoilage and extended the shelf-life of produce (Cagri et al., 2004). For example, bilayer of chitosan and polyethylene wax containing natamycin prolonged shelf-life of Hami melon up to 20 days of shelf-life at 30 °C and 70 % RH, particularly in reducing decay area (Cong et al., 2007).

2.5.2.5 Ethylene removal

Ethylene increases respiration, ripening and senescence that cause postharvest loss of fresh FV (Vermeiren et al., 1999). In order to extend the shelf-life of fruits and vegetables, removal of ethylene from storage room and packaging is necessary (Zagory, 1995). Many studies were conducted to inhibit the negative effects of ethylene on fruits and vegetables including kiwi (Abe and Watada, 1991), banana (Terry et al., 2007),

avocado (Meyer and Terry, 2010), apple (Ponce et al., 2002), tomato (Sammi and Masud, 2007), melon (Aharoni et al., 1993) and papaya (Silva et al., 2009). Various ethylene removal techniques were applied (Conte et al., 1992).

- Ventilation by external air is the easy way used for storage rooms under normal atmospheric conditions.

- C₂H₄-adsorbing with chemical oxidants (potassium permanganate on inert substrates) has been used commercially (Conte et al., 1992). Potassium permanganate (KMnO₄) oxidizes ethylene and there was a color change in this reaction, from purple to brown (Vermeiren et al., 1999). The advantage of this method was that ethylene level was reduced rapidly, but it was only used in small volume room and with low ethylene producing fruit.

- With large volume rooms, catalytic oxidation was applied.

- Ethylene scavenging was also adopted in household refrigerators. Zeolite coated with KMnO₄ were used in consumer fridge (Vermeiren et al., 1999).

- In packaging, C₂H₄-adsorbing substances were introduced. They were convenient to use due to supplying as sachets or integrating into films (Vermeiren et al., 1999). Sachets containing 4-6 % KMnO₄ on different supports such as alumina, silica gel or activated carbon (Zagory, 1995) are easy to apply.

2.5.2.6 Storage temperature

Low temperatures have been applied in postharvest management to slow the biological processes of fruit (Paliyath et al., 2009).

Yang et al. (2003) carried out the experiment with three melon cultivars: New Queen, 8601 and Kalakusai at different maturity stages. Melons were stored at 1, 3, 5, 7 and 22 °C. There were clear differences in sensitivity to chilling injury (CI) among three cultivars at different temperatures between 22 and 1 °C. The results also showed that the middle or late-maturing cultivars of Hami melon had more endurance to CI. The suitable temperature range of Hami melon is 3-7 °C for long storage.

Another research also evaluated the effect of temperature on six melon cultivars (Miccolis et al., 1995). Six inodorous melon cultivars were stored at 7, 12, 15 °C for 3 weeks and plus three days at 20 °C. The rate of softening depended on cultivar. Melons stored at 15 °C were softer than those at 7 °C. Weight loss increased in case of high temperatures and storage period. Pitting symptoms appeared first for melons stored at 7 °C and then for fruits stored at 12 and 15 °C, whereas senescent blemishes only occurred for fruits stored at 12 or 15 °C.

3. RESEARCH OBJECTIVE

3.1 Research objective

The objective of this study was to find the possible postharvest management including 1-MCP application, storage condition and washing treatment for extending the storability of melon. Accordingly, three main practical tasks have been conducted to comply with the objective:

- i. Investigating the potential effect of 1-MCP application on four melon cultivars at different temperatures and days after harvest.
- ii. Evaluating the innovative technique such as 1-MCP microbubbles for treatment and ozone microbubbles for washing melon.
- iii. Examining the effect of the ethylene absorber as well as gaseous ozone treatment during storage.

3.2 Research questions

In order to reach the research objective, some relevant questions have been deliberated:

- i. Do different treatment temperatures of 1-MCP have effect on four melon cultivars?
- ii. Does delayed application of 1-MCP have impact on four melon cultivars?
- iii. Are there any effects of 1-MCP microbubbles treatment on melon?
- iv. Do storage conditions such as ethylene absorber or ozone treatment maintain the quality of melon during storage?
- v. Does the combination of 1-MCP and ethylene absorber or 1-MCP and ozone have efficacy on melon during storage?
- vi. Do hot water, chlorine, hot water and microbubbles, chlorine and microbubbles, and ozone microbubbles reduce microbial counts on melon skin?

3.3 Research scope

This study has conducted on four melon cultivars in Hungary.





4. MATERIALS AND METHODS

4.1 Materials and methods

4.1.1 Melon

Melons (*Cucumis melo* L. var. *reticulatus* Naud.) were bought from an experienced grower in Hungary. Fruits were harvested from June to September 2014 and 2015 at the $\frac{1}{2}$ - $\frac{3}{4}$ slip stage and transported to the Faculty of Food Science in Budapest, Hungary. Four melon cultivars comprising Lillo, Centro, Celestial, and Donatello were examined (Table 9). Fruits were selected for uniformity of size, shape and freedom from external damage. The average weight of each piece was 1.0 ± 0.2 kg, the average small diameter and large diameter are 12.0 ± 0.3 cm and 14.0 ± 0.2 cm, respectively. The sample size would be described in each experiment detail.

Table 9. Characteristics of four melon cultivars

Cultivar	Photo	Characteristics
Donatello	 <p>source: www.szatmarivetomag.hu</p>	<ul style="list-style-type: none"> - Orange flesh - Netted rind - Average weight 1.5-2 (kg)
Centro	 <p>source: www.szatmarivetomag.hu</p>	<ul style="list-style-type: none"> - Orange flesh - Netted rind - Average weight 1.5-1.8 (kg)
Lillo	 <p>source: www.mezogazdasagibolt.hu</p>	<ul style="list-style-type: none"> - Orange flesh - Netted rind - Average weight 1.5-2 (kg)
Celestial	 <p>source: www.mezogazdasagibolt.hu</p>	<ul style="list-style-type: none"> - Orange flesh - Netted rind - Average weight 1.3-1.8 (kg)

4.1.2 Maturity stages (Fig. 12-14)

The abscission zone or slip is useful to determine the maturity of this fruit (Bett-Garber et al., 2003).

Slip and cantaloupe ripeness (Fig. 12)

- (1) Full size melon. No slip; “pull” fruit.
- (2) Slip just starting, near ¼ slip. Requires high thumb force to push stem from fruit.
- (3) ½- ¾ slip, melon can be pushed with moderate thumb pressure from stem.
- (4) Full slip, stem scar with fresh appearance; stem easily pushed from fruit.
- (5) Slip occurred day prior, very dry stem end; melon may be soft.

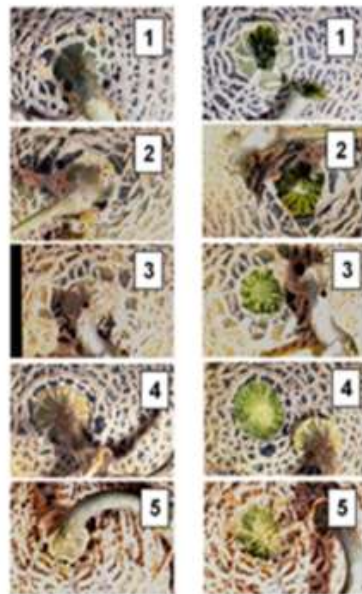

Figure 12. Slip and cantaloupe ripeness (source: Postharvest Technology Center, UC Davis, USA)



Figure 13. Full ripe cantaloupe (source: Postharvest Technology Center, UC Davis, USA)

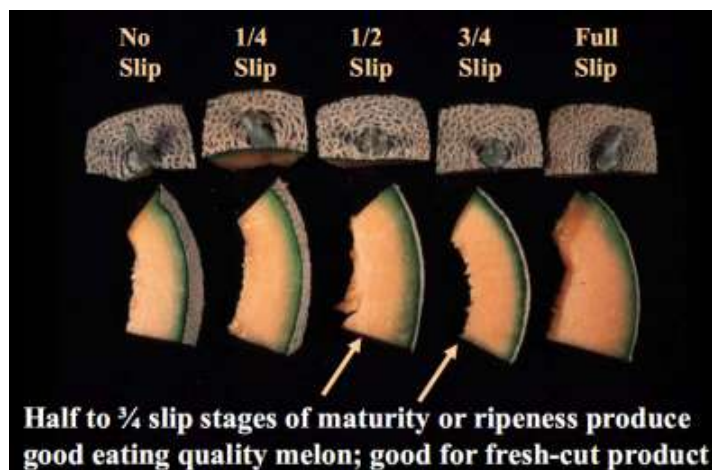

Figure 14. Flesh color regarding maturity stages (Cantwell, 2004)

4.2 Measurements

The changes of melon quality during storage and shelf-life were measured by nondestructive methods: acoustic firmness measurement, skin surface color and chlorophyll fluorescence measurement. Besides, ethylene and CO₂ production, disease incidence, chilling injury, mesophilic aerobes, and disease severity were also determined.

4.2.1 Ethylene production

Ethylene production was determined by an ICA-56 hand-held ethylene analyzer (International Controlled Atmosphere Ltd., United Kingdom) upon the measured ethylene production of the samples being held for a given time in a hermetically closed plastic container. The measurement was carried out as following: one kilogram of melon was put in a plastic box, then the box was closed. After 1h, the ethylene production of fruits was measured in ppm (Figs. 15-16.). Results were expressed in microliter of ethylene produced per kilogram of fruit in 1 h ($\mu\text{l}\cdot\text{kg}^{-1}\cdot\text{h}^{-1}$).

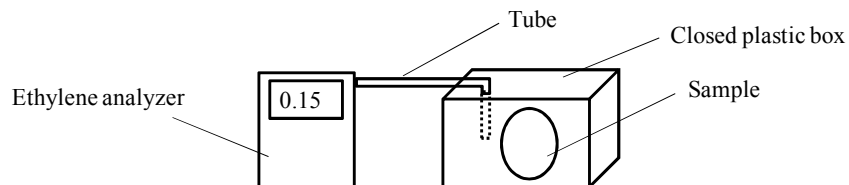

Figure 15. Schematic diagram of ethylene measurement



Figure 16. Hand-held ethylene analyzer and plastic containers for ethylene measurement

4.2.2 CO₂ production

Respiratory intensity as carbon dioxide production was measured for an hour in a closed respiratory system containing several hermetically closed plexi glass containers equipped with FY A600-CO₂H carbon dioxide sensors connected to an Almemo 3290-8 data logger (Ahlborn Mess-und Regelungstechnik GmbH, Germany). The measurement was conducted as following: one kilogram of melon and carbon dioxide sensors were put in a plexi glass container, then the container was closed. The data logger continuously recorded the carbon dioxide production for 45 min (Figs. 17-18). Results were expressed in milliliter of CO₂ produced per kilogram of fruit in 1 h ($\text{ml} \cdot \text{kg}^{-1} \cdot \text{h}^{-1}$)

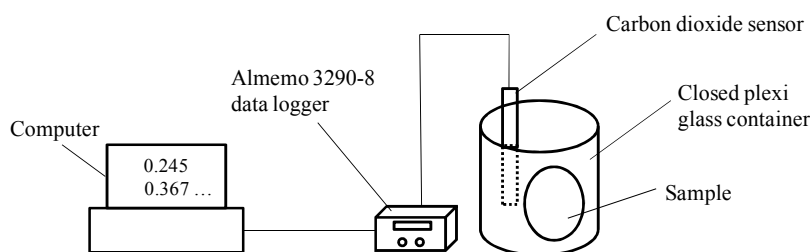

Figure 17. Schematic diagram of respiration measurement



Figure 18. Respiration system containing the FY A600-CO₂H carbon dioxide sensors connected to an Almemo 3290-8 data logger

4.2.3 Acoustic firmness

The principle of this method is based on determining the resonant frequency of fruit after inducing mechanical excitation on sample. When fruit was excited, acoustic response was measured by a sensing device and analyzed by fast Fourier-transformation to extract the resonant frequencies. The stiffness depends on mass of the sample and resonant frequency of the excited sample (De Ketelaere et al., 2006).

Acoustic firmness (Stiffness, $\text{Hz}^2 \cdot \text{g}^{2/3}$) of samples was determined at two opposite sides on the exterior circumference of each fruit, using an AWETA table top acoustic firmness sensor model DTF V0.0.0.105 (AWETA, Nootdorp, The Netherlands) (Figs. 19-20). The acoustic firmness measurement was carried out as following: melons were placed on sample holder, firstly AWETA table top measured the weight of the product, followed by a gentle tap at the melon. Then, the microphone recorded the signal and the system automatically selected the highest peak in the frequency spectra. The acoustic signal of sample was analyzed and together with the weight, the acoustic firmness and impact firmness of product were determined. The acoustic firmness was calculated: $S = f^2 m^{2/3} [1]$ (De Ketelaere et al., 2006).

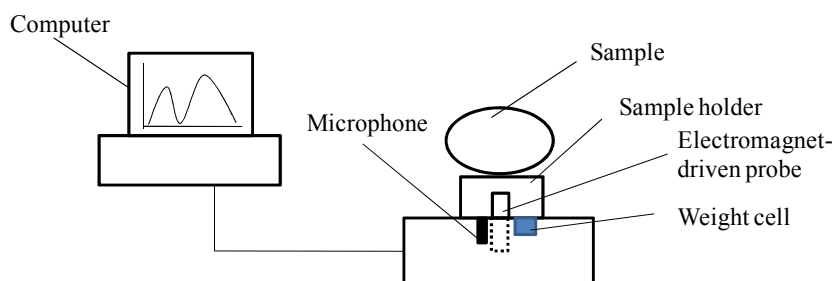

Figure 19. Schematic diagram of acoustic firmness measurement



Figure 20. AWETA table top acoustic firmness sensor

4.2.4 Chlorophyll fluorescence analysis

Chlorophyll fluorescence analysis is a non-destructive method that has been applied widely in the photosynthesis activity measurement of sample. Absorbed energy by chlorophyll molecules can be used for three processes including driving the photosynthesis (photochemistry), dissipating as heat or emission as chlorophyll fluorescence. Many commercially available chlorophyll fluorometers have been invented, however, Pulse Amplitude Modulated (PAM) was one of the most common fluorometers utilized in laboratories (Gorbe and Calatayud, 2012).

Chlorophyll fluorescence parameters were determined at three equidistant points on the external circumference of each fruit by a PAM WinControl-3 controlled MONI-PAM multi-channel chlorophyll fluorometer (Heinz Walz GmbH, Germany) (Figs. 21-22). The measurement was conducted as following: melons were placed on sample holder, Moni-PAM head flashed blue light (measuring light) at three different points of each sample (Fig. 21). Obtained data were minimal, maximal, variable chlorophyll fluorescence (F_0 , F_m , F_v) and potential quantum yield of photosystem II (F_v/F_m).

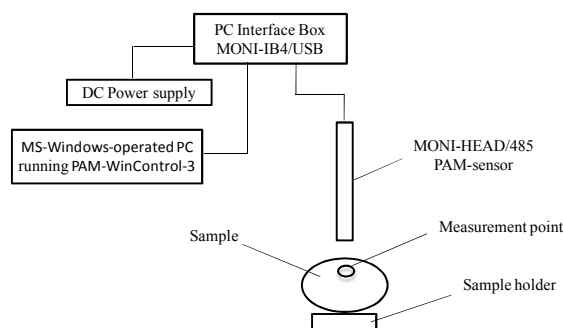

Figure 21. Schematic diagram of chlorophyll fluorescence parameters measurement



Figure 22. Chlorophyll fluorescence measurement system

4.2.5 Surface color measurement

Melon peel color was measured with a portable Minolta Chroma Meter CR-400 (Minolta Corporation, Osaka, Japan). CIE L^* , a^* and b^* color characteristics were determined at three equidistant points on the external circumference of each fruit. Hue angle (H°) value was calculated as arctangent (b/a) (Figs. 23-24).

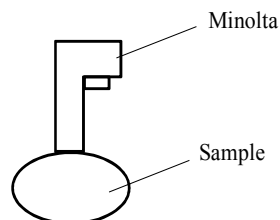

Figure 23. Schematic diagram of surface color measurement



Figure 24. Minolta Chroma Meter CR-400

4.2.6 Chilling injury (CI) evaluation

CI symptom was determined by sensory evaluation as brownish pitting and water-soaked areas on melon rind surface and evaluated by the scale of 1-5, where: (1) no CI; (2) CI area $\leq 10\%$; (3) CI area from 11 to 25%; (4) CI area from 26 to 50%; (5) CI area $\geq 50\%$ (Yang et al., 2003).

4.2.7 Decay percentage evaluation

Decay was evaluated by sensory evaluation as fungal mycelia appeared on stem or melon surface and calculated as the number of decayed samples divided by initial number of samples multiplied by 100.

4.2.8 Disease severity evaluation

Mould growth on melon rind or stem were tested during the storage period, and assessed by scale of 1-3 (Yang et al., 2003), where 1 = good, fruit without decay (without mould on the rind or stem), 2 = fair, fruit with moderate decay (one or two fungal spots on melon rind or stem with 0.5 – 1 cm diameter); 3 = bad, fruit with severe decay (one or more fungal spots on melon rind or stem with more than 1.0 cm diameter). Disease severity was calculated as average score of all melon within a group.

4.2.9 Mesophilic aerobes analysis

Gauze balls were humidified by sterile distilled water before sampling. Sampling was taken at sides without decay on melon rinds with metallic ring ($d=36.5$ mm, $A=10.41$ cm²) (Fig. 25). After sampling, gauze balls were packed in sterile polyethylene bags kept at -10 °C for analysis later on. Three sides on each melon surface were sampled and three fruits were used to evaluate the survival of microorganisms for each treatment. Gauze balls were put in 0.1 % peptone water, then 1 milliliter of dilutions (peptone water) 10^{-1} , 10^{-2} and 10^{-3} were plated in Plate Count Agar. Mesophilic aerobes were determined after 48 h incubation Plate Count Agar at 35 °C (Fig. 25).

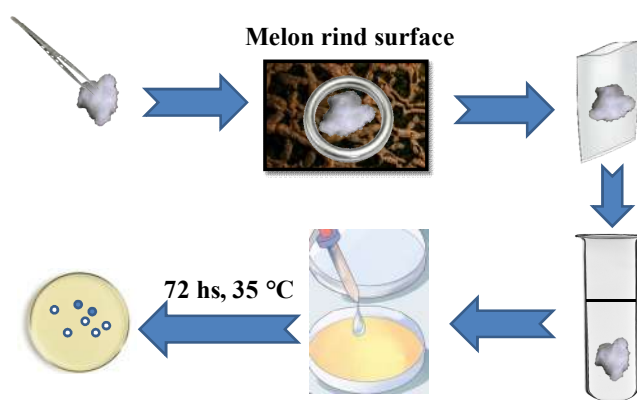

Figure 25. Sampling and mesophilic aerobes analysis procedure

4.3 1-Methylcyclopropene (1-MCP)

1-MCP (tablet, SmartFresh[®], AgroFresh, Philadelphia, USA) as an application of SmartFresh[®] system was provided by Agrofresh Polska Sp.z.o.o.

Chemical formula: C₄H₆. Molar mass: 54 g/mol

Chemical structure (Fig. 26)

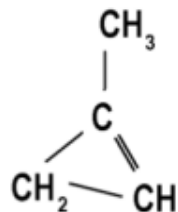

Figure 26. Chemical structure of 1-MCP molecule

4.3.1 Application of 1-MCP gaseous form (conventional 1-MCP)

Fruits were treated with 1-MCP gas released from 1-MCP tablet in 15 ml activator solution for 24 h in an air-tight plastic box (Figs. 27-28). Small fan was used to mix the air in the box. The initial 1-MCP concentration in the box was 1.2 ppm.

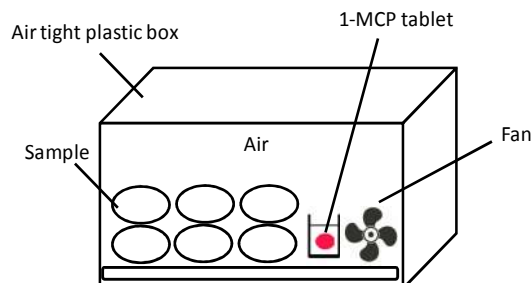

Figure 27. Schematic diagram of conventional 1-MCP application



Figure 28. Commercially available air-tight plastic box for the 1-MCP applications

4.3.2 Application of 1-MCP microbubbles (1-MCP MBs)

1-MCP MBs generation system was built up for postharvest treatment in this work as shown in Fig. 29. 1-MCP gas was prepared in 5 L closed glass for 45 min before application. Gaseous 1-MCP was released from 1-MCP tablet (at concentration 300-350 ppb/m³) with 15 ml activator solution. Seventy liters of water (pH = 7-8) were poured into a 250 L plastic box and melons were added. Then, 1-MCP gas was pumped into circulating water at flow rate 100 liters/min by opening valve 1. 1-MCP MBs were produced by gas liquid mixing pump adjusted by valve 2, pressure 5-6 bar (Gas liquid mixing pump Type: YL8022, model: 25GO-2SS, 1.1 KW, Guangzhou Ozone Environmental Technology Co., Ltd, China). 1-MCP MBs turned water in the box from transparent to milky appearance. Treatment time was 15, 30 and 45 min. Treatment conditions: water temperature 16 - 20 °C, pH= 7-8 (Fig. 29).

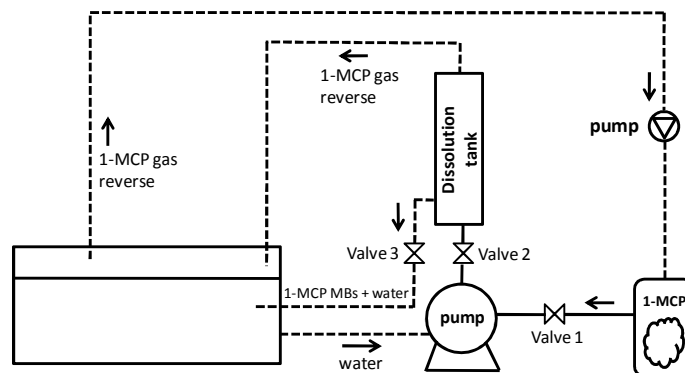

Figure 29. Schematic diagram of 1-MCP MBs generation system

4.4 Ethylene absorber (EA)

Sachets of Ethyl Stopper containing KMnO_4 were provided by Bioconservacion S.A., Spain. These sachets were used as ethylene absorber during storage. Recommendation of supplier is one sachet of ethylene absorber for 3-10 kg fruits. Sachets of Ethyl Stoppers were placed along with produce throughout cold storage (Fig. 30).



Figure 30. Sachets of Ethyl Stopper

(source: <http://www.bioconservacion.com/en>)

Potassium permanganate removes ethylene as the following reaction ([2]):

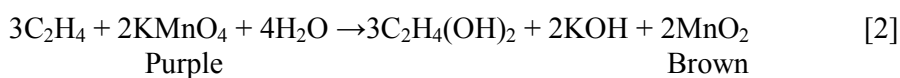

Experiment 2 would introduce ethylene absorber treatment in detail.

4.5 Chlorine

Chlorine as a sanitizing agent was provided by The Fishmarket Kft. (Budaörs, Hungary). Free chlorine concentration was measured with chlorine test kit (Hanna Instrument, free chlorine reagent HI93701-0, Romania). The initial concentration of chlorine in the chlorinated water was 280 ppm. Chlorine solution was diluted to 150 ppm for treatments.

Experiment 3 would introduce chlorine treatment in detail.

4.6 Ozone (used in experiment 2)

Ozone was generated by commercially ozone generator (Neo.Tec XJ-100, China) designed for the household use in refrigerators (Fig. 31).

In this work, gaseous ozone 0.1ppm/h in storage experiment was used for two purposes: ethylene removal and sanitizing during cold storage.



Figure 31. Neo.Tec XJ-100 ozone generator for the household use
(source: <http://neotecir.com>)

Ozone eliminates ethylene as the following reaction ([3]):

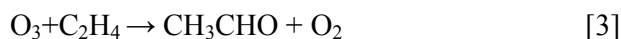

Experiment 2 would introduce ozone treatment in detail.

4.7 Microbubbles generation system for washing treatment

4.7.1 Ozone microbubbles generation system

Ozone microbubbles (ozone MBs) generation system was built up for washing melon in this work as shown in Fig. 32. Seventy liters tap water (pH = 7-8, t = 16 °C) was poured into a 250 L plastic box and melons were added. Gaseous ozone at the concentration of 150 ppm was produced by ozone generator (GO-R 5G, Guangzhou Ozone Environmental Technology Co., Ltd, China). Then, the mixture of ozone and air was pumped into circulating water at flow rate 100 liters/min by opening valve 1. Ozone MBs were produced by gas liquid mixing pump adjusted by valve 2 (Gas liquid mixing pump Type: YL8022, model: 25GO-2SS, 1.1 KW, Guangzhou Ozone Environmental Technology Co., Ltd, China). Ozone MBs turned water in the box from transparent to milky appearance. Treatment time was 2, and 5 min. Treatment conditions: water temperature 16 °C, pH = 7 – 8 (Figs. 32-33).

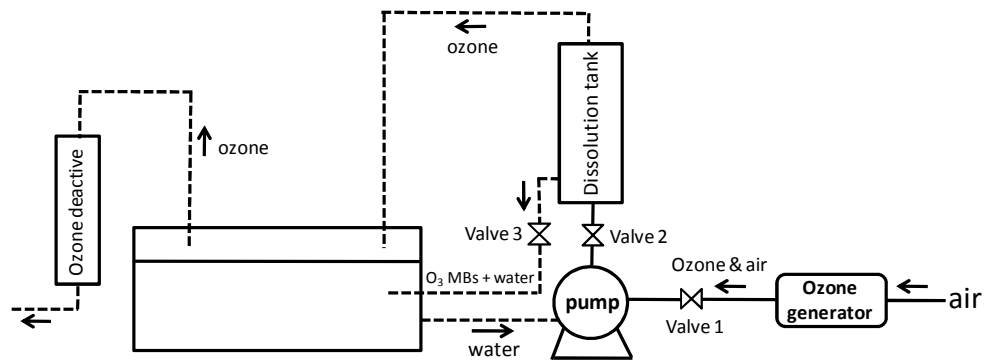

Figure 32. Schematic diagram of ozone microbubbles generation system



Figure 33. Washing treatment with ozone microbubbles generation system

4.7.2 Hot water and microbubbles

The system was built up for the combination of hot water and microbubbles washing treatment as shown in Fig. 34. Seventy liters hot water (pH = 7 - 8, $t = 55\text{ }^{\circ}\text{C}$) was poured into a 250 L plastic box and melons were added. Air was pumped into circulating water at flow rate 100 liters/min by pump. The flow rate was adjusted by valve 1. Air MBs were produced by gas liquid mixing pump adjusted by valve 2 (Gas liquid mixing pump Type: YL8022, model: 25GO-2SS, 1.1 KW, Guangzhou Ozone Environmental Technology Co., Ltd, China). Microbubbles turned water in the box from transparent to milky appearance. Treatment time was 2, and 5 min. Treatment conditions: water temperature $55\text{ }^{\circ}\text{C}$, pH = 7 - 8 (Fig. 34).

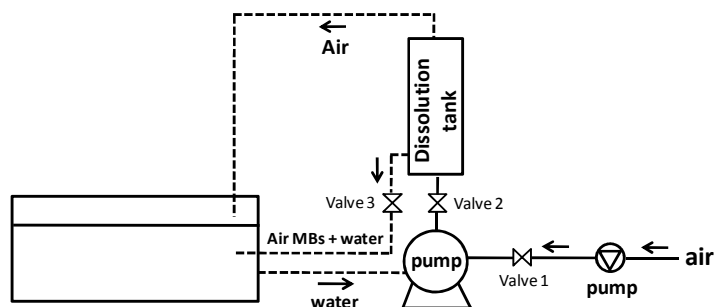

Figure 34. Schematic diagram of hot water and microbubbles generation system

4.7.3 Chlorinated water and microbubbles

The system built up for the combination of chlorine and microbubbles washing treatment was similar to that of the combination of hot water and microbubbles, but in this case hot water was replaced by chlorinated water. Treatment time was 2, and 5 min. Treatment condition: water temperature was 16 °C.

4.8 Experimental design

Experiments of this research are schematically summarized in the flow chart as shown in Fig.35.

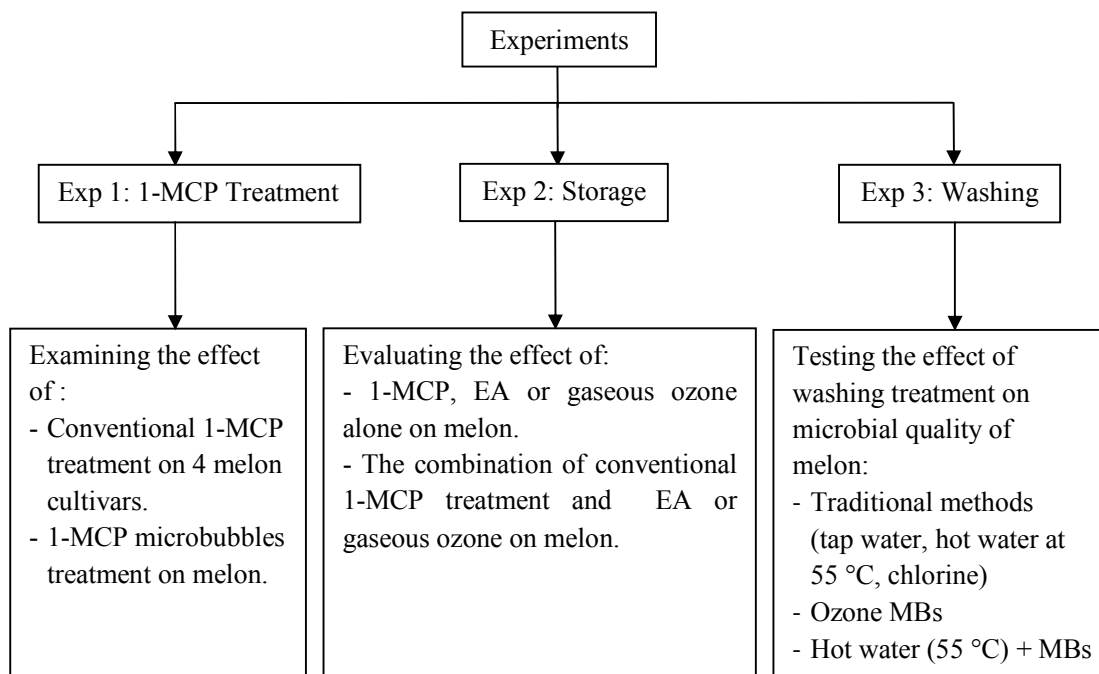

Figure 35. Experimental design

There were three experiments carried out as below:

Experiment 1: Efficacy of 1-MCP application including conventional 1-MCP (1-MCP gaseous form) and 1-MCP microbubbles on melon was tested.

Experiment 2: Effect of conventional 1-MCP treatment, ethylene absorber and ozone treatment on melon was evaluated.

Experiment 3: Different washing methods: tap water, hot water (at 55 °C), chlorine, ozone microbubbles, the combination of hot water and microbubbles or chlorinated water and microbubbles were investigated.

The procedure of each experiment would be detailed as below.

4.8.1 Experiment 1: Evaluating the effect of 1-MCP treatment on melon

4.8.1.1 Experiment 1.1: Application of conventional 1-MCP at different temperatures

Experiment 1.1 could answer the questions:

- Whether or not 1-MCP has effect on melon?
- Are there any differences among different treatment temperatures: 5 °C, 10 °C, and 20 °C on 4 melon cultivars during shelf-life?

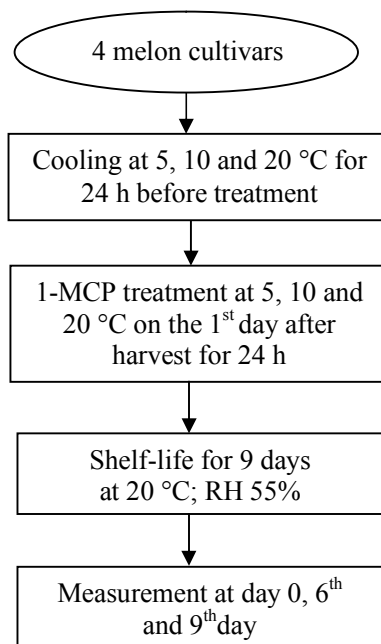

Figure 36. Application of conventional 1-MCP at different temperatures on the 1st day after harvest

Four melon cultivars including Centro, Lillo, Celestial and Donatello were tested. Samples of each cultivar were selected randomly into 4 groups: 3 treated groups and 1 untreated group (control). Each group contained 15 fruits. Fruits were treated with 1-MCP gas in an air-tight plastic box for 24 h (as shown in Fig. 27).

Three groups were kept for 24 h at 5, 10 and 20 °C before treatment. These groups were treated with 1-MCP at 5, 10 and 20 °C, respectively on the 1st day after harvest, whereas control melons were kept at 5 °C till the application was completed. After 1-MCP treatment, three treated groups and control were stored at room temperature (20 °C, RH 55 %) for 9 days (Table 10).

Table 10. Application of 1-MCP at different temperatures

Day \ Sample	0 (Harvest)	1	2	3	4	5	6	7	8	9
1-MCP _{5°C}	M, C _{5°C}	T _{5°C}	SL	SL	SL	SL	SL, M	SL	SL	M
1-MCP _{10°C}	M, C _{10°C}	T _{10°C}	SL	SL	SL	SL	SL, M	SL	SL	M
1-MCP _{20°C}	M, C _{20°C}	T _{20°C}	SL	SL	SL	SL	SL, M	SL	SL	M
Control	M, C _{5°C}	C _{5°C}	SL	SL	SL	SL	SL, M	SL	SL	M

1-MCP_{5, 10, 20 °C}: 1-MCP application was carried out at 5, 10 and 20 °C, respectively.

C_{5, 10, 20 °C}: Cooling at 5, 10 and 20 °C, respectively.

T: Treated with 1-MCP for 24 h

SL: Shelf-life at 20 °C; M: measurement at 20 °C

Measurement

Measurements of ethylene production, respiration, acoustic firmness, surface color, chlorophyll fluorescence parameters and disease severity were carried out at day 0, then 6th and 9th day at 20 °C.

4.8.1.2 Experiment 1.2: Application of conventional 1-MCP at different days

Experiment 1.2 could answer the following two questions:

- Whether or not the delay of 1-MCP has effect on 4 melon cultivars ?
- After harvest, how many days could 1-MCP treatment delay ?

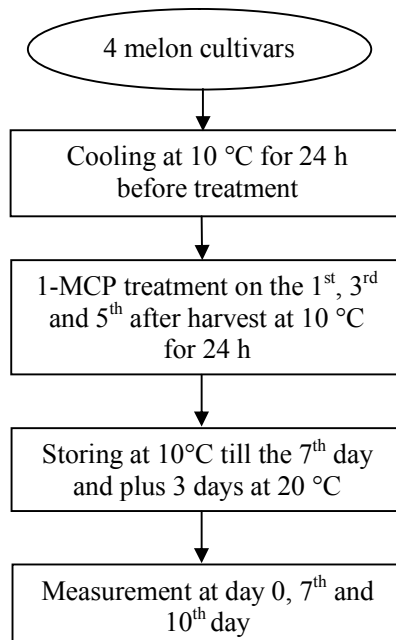

Figure 37. Application of conventional 1-MCP at different days after harvest

Four melon cultivars including Centro, Lillo, Celestial and Donatello were tested. Samples of each cultivar were selected randomly into 4 groups: 3 treated groups and 1 untreated group (control). Each group contained 15 fruits. Fruits were stored at 10 °C before treatment. Three groups were treated with 1-MCP gas on the 1st, 3rd and 5th day after harvest, respectively in an air-tight plastic box at 10 °C for 24 h (Fig. 27). During treatment period, control group (untreated) was kept at 10 °C. After 1-MCP application, 4 groups were kept at 10 °C, RH 90 - 95 % till the 7th day and then transferred to 20 °C for 3 days of shelf-life.

Table 11. Application of 1-MCP at different days after harvest

Day Sample	0 (Harvest)	1	2	3	4	5	6	7	8	9	10
1-MCP _{1st}	M, C	T	C	C	C	C	C	M, SL	SL	SL	M
1-MCP _{3rd}	M, C	C	C	T	C	C	C	M, SL	SL	SL	M
1-MCP _{5th}	M, C	C	C	C	C	T	C	M, SL	SL	SL	M
Control	M, C	C	C	C	C	C	C	M, SL	SL	SL	M

1-MCP_{1st, 3rd, 5th} : 1-MCP application was carried out at day 1, 3 and 5 after harvest, respectively.

C: Cooling at 10 °C; T: Treated with 1-MCP, 24 h at 10 °C

SL: Shelf-life at 20 °C; M: measurement at 20 °C

Measurement

The same measurements of experiment 1.1 were performed at day 0, then 7th and 10th day at 20 °C.

4.8.1.3 Experiment 1.3: Application of 1-MCP microbubbles (1-MCP MBs)

Experiment 1.3 could answer the question:

- Whether or not 1-MCP microbubbles have effect on ‘Donatello’ melon ? In addition, the efficacy of conventional 1-MCP and 1-MCP microbubbles treatment were compared.

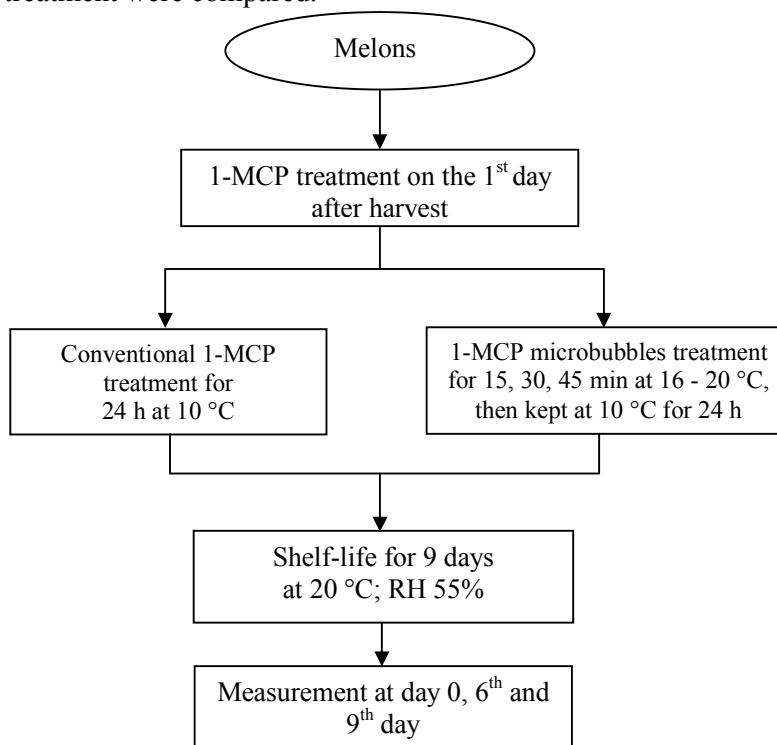

Figure 38. Application of conventional 1-MCP and 1-MCP MBs on ‘Donatello’ melon

‘Donatello’ melons were selected randomly into 5 groups: 1 untreated group (control) and 4 treated groups comprising 1 group treated with 1-MCP gas form and 3 groups treated with 1-MCP MBs. Each group contained 15 fruits. Melons were kept at 10 °C before treatment. Fruits were treated with 1-MCP (including conventional 1-MCP or 1-MCP MBs) on the 1st day after harvest as shown in Table 12.

Application of conventional 1-MCP (gaseous form)

One group was treated with 1-MCP gas in an air-tight plastic box at 10 °C for 24 h (as shown in Fig.27). Control group was still kept at 10 °C during 24 h long treatment of gaseous 1-MCP.

Application of 1-MCP MBs

Three groups were dipped in tap water containing 1-MCP MBs for 15, 30 and 45 min, respectively (detailed in 4.3.2). Then, three groups treated with 1-MCP MBs were kept at 10 °C for 24 h.

Shelf-life

On the second day after harvest, all samples were stored at 20 °C, RH 55 % for 9 days of shelf-life.

Measurements

The ethylene and CO₂ production, and disease severity were measured on day 0, 3rd, 6th and 9th day at 20 °C. Acoustic firmness, surface color and chlorophyll fluorescence parameters were measured on day 0, 6th and 9th day at 20 °C.

Table 12. Application of 1-MCP on ‘Donatello’ melon

Day Sample	0 (Harvest)	1	2	3	4	5	6	7	8	9
1-MCP _{24h}	M, C	T	SL	SL	SL	SL	SL, M	SL	SL	M
1-MCP MBs _{15min}	M, C	T, C	SL	SL	SL	SL	SL, M	SL	SL	M
1-MCP MBs _{30min}	M, C	T, C	SL	SL	SL	SL	SL, M	SL	SL	M
1-MCP MBs _{45min}	M, C	T, C	SL	SL	SL	SL	SL, M	SL	SL	M
Control	M, C	C	SL	SL	SL	SL	SL, M	SL	SL	M

1-MCP MBs_{15, 30, 45 min}: 1-MCP MBs application was carried out for 15, 30 and 45 min, respectively.

1-MCP_{24 h}: conventional 1-MCP application was conducted at 10 °C for 24 h

C: Cooling; T: Treated with 1-MCP

SL: Shelf-life at 20 °C; M: measurement at 20 °C

4.8.2 Experiment 2: Evaluating the effect of 1-MCP, ethylene absorber and ozone

In the experiment 2, the following questions would be answered:

- Whether or not the ethylene absorber or gaseous ozone treatment have effect on ‘Donatello’ melon ?
- Whether or not the combination of 1-MCP and ethylene absorber or gaseous ozone treatment have effect on ‘Donatello’ melon ?

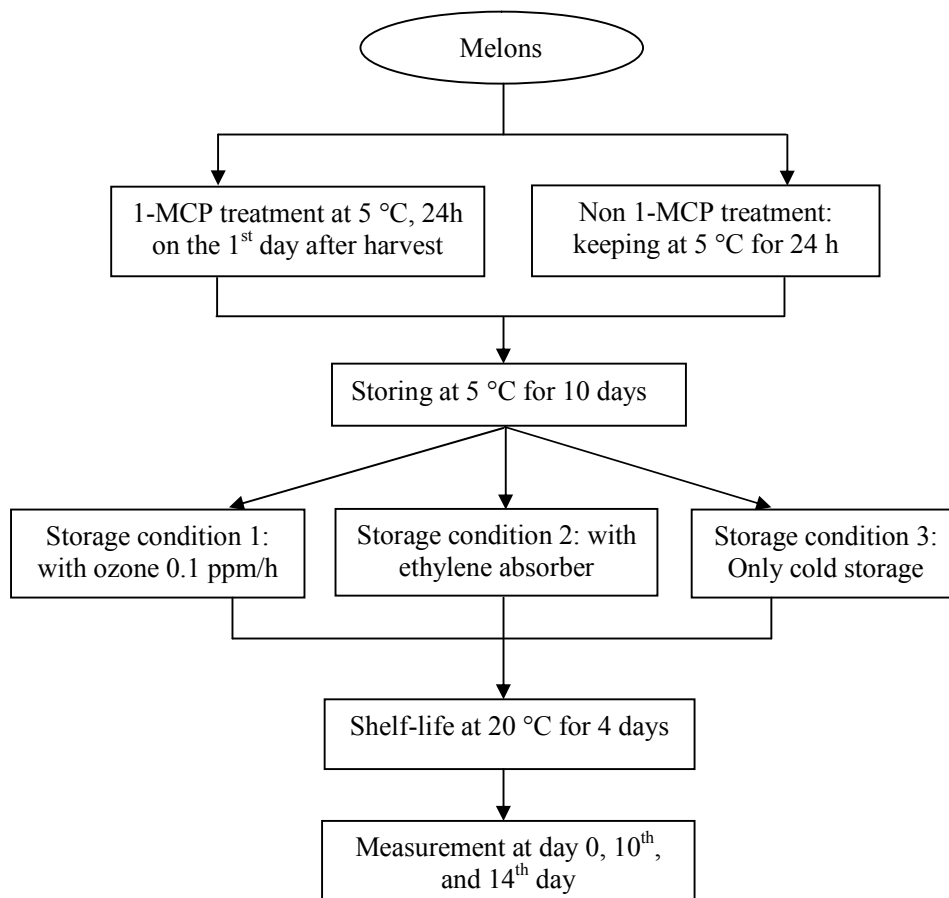

Figure 39. 1-MCP application and storage conditions on ‘Donatello’ melon

Application of 1-MCP gaseous form

‘Donatello’ melons were divided randomly into 6 groups. Each group contained 15 fruits. Melons were cooled down to 5 °C before treatment. Three groups were treated with gaseous 1-MCP at 5 °C on the 1st after harvest for 24 h (as shown in Fig. 27).

Storage conditions

During 24 h long treatment, three non 1-MCP treated groups were stored separately at 3 different storage conditions:

Storage condition 1: cold storage at 5 °C + ozone 0.1 ppm/h.

Storage condition 2: cold storage at 5 °C + 6 sachets of Ethyl Stopper.

Storage condition 3: only cold storage at 5 °C.

After 1-MCP application, three 1-MCP treated groups were put into 3 different storage conditions above (Table 13). Thus, each storage condition had 2 groups: one 1-MCP treated group and one non 1-MCP treated group. All six groups were stored during 10 days at 5 °C, and then transferred to 20 °C for 4 days of shelf-life.

Table 13. Storage and shelf-life condition

Storage condition		Sample
Cold storage at 5 °C for 10 days	Gaseous ozone 0.1ppm/h	1-MCP treated group
		Non 1-MCP treated group
	Ethyl Stopper	1-MCP treated group
		Non 1-MCP treated group
Shelf-life for 4 days	Cold storage at 5 °C at 20 °C	1-MCP treated group
		Non 1-MCP treated group
		6 groups

Measurement

The disease severity and chilling injury were measured on day 0, 4th, 8th, 10th, and 14th day.

The ethylene and CO₂ production, acoustic firmness, surface color and chlorophyll fluorescence parameters were measured on day 0, 10th and 14th day.

4.8.3 Experiment 3: Evaluating the efficacy of washing treatments

Experiment 3 would answer the question:

- Whether or not washing treatments decrease the microbial populations on melon rind?

In this experiment, different sanitizers were investigated. Melons were submerged in sanitizing solutions for 2 or 5 min. Treatments was presented in Fig. 40.

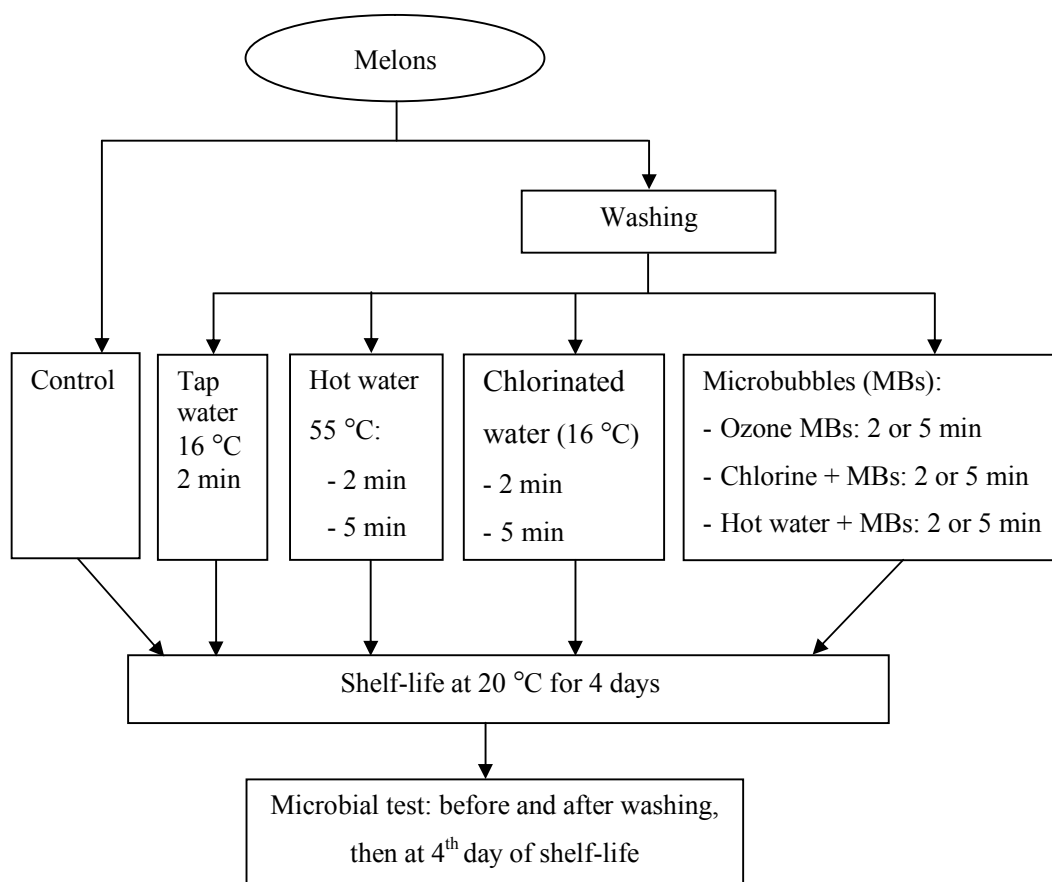

Figure 40. Washing treatment design

Treatments

‘Donatello’ melons were randomly divided into 12 groups: 11 treated groups and 1 untreated group. Each group contained 10 fruits. Treatments were carried out in detail as following (Table 14).

- Unwashed samples served as control.
- Fruits were dipped in tap water for 2 min.
- Samples were washed with hot water at 55 °C or chlorinated water 150 ppm for 2 and 5 min, respectively.
- Melons were submerged in tap water containing ozone MBs for 2 or 5 min, respectively at 16 °C (described in 4.7.1).
- Hot water and MBs or chlorinated water and MBs were also tested. Fruits were immersed in hot water at 55 °C containing MBs for 2, and 5 min or chlorinated water (16 °C) 150 ppm containing MBs for 2, and 5 min (detailed in 4.7.2).

All samples were air-dried after treatment and then kept at 20 °C for 4 days of shelf-life.

Table 14. Treatment depiction

Washing treatment	Treatment depiction
Control	Control
Tap water	TW
Hot water 2min	HW 2 min
Hot water 5min	HW 5 min
Hot water + MBs 2 min	HW MBs 2 min
Hot water + MBs 5 min	HW MBs 5 min
Chlorinated water 2 min	Clo 2 min
Chlorinated water 5 min	Clo 5 min
Chlorine + MBs 2 min	Clo MBs 2 min
Chlorine + MBs 5 min	Clo MBs 5 min
Ozone microbubbles 2 min	O ₃ MBs 2 min
Ozone microbubbles 5 min	O ₃ MBs 5 min

Measurement

Mesophilic aerobes analysis, disease incidence and disease severity were evaluated before treatment, after treatment and at 4th day of shelf-life.

4.9 Statistical analysis

All data were processed by SPSS (SPSS Inc, USA) using analysis of variance (ANOVA), followed by Tukey's method with significance level of $p < 0.05$. The results were reported with mean and standard deviation.

In the experiment 1.1, ANOVA with the following factors: treatment temperatures (5 °C, 10 °C and 20 °C), cultivars (Lillo, Centro, Celestial, and Donatello) and storage time (0, 6 and 9 days) were tested.

In the experiment 1.2, ANOVA with the following factors: treatment days (1st, 3rd and 5th day), cultivars (Lillo, Centro, Celestial, and Donatello) and storage time (0, 7 and 10 days) were tested.

In the experiment 1.3, ANOVA with the following factors: treatment type (gaseous 1-MCP, 1-MCP MBs: 15 min, 30 min and 45 min) and storage time (0, 3, 6, and 9 days) were tested.

In the experiment 2, ANOVA with the following factors: treatment type (1-MCP, untreated); storage condition (ozone and ethylene absorber treatment) and storage time (0, 10 and 14 days) were tested.

In the experiment 3, ANOVA with the following factors: washing treatment type (11 treatments and 1 control) and storage time (after treatment and at the 4th day of shelf-life) were tested.

5. RESULTS AND DISCUSSION

5.1 Effect of 1-MCP treatment on melon during storage

5.1.1 Effect of different treatment temperatures

Ethylene and CO₂ production

The initial ethylene concentration had a wide range among four cultivars, approximately from 36 $\mu\text{L kg}^{-1}\text{h}^{-1}$ to 46 $\mu\text{L kg}^{-1}\text{h}^{-1}$ (Fig. 41). Lillo had the lowest ethylene production followed by Donatello, Celestial and Centro. Ethylene production of both untreated and treated fruits also decreased, but at different rates. The control fruits showed a gradual decline, while treated fruits had a strong decrease in ethylene production during storage (Fig. 41). This reflected a response of melons to 1-MCP. Similar results were also reported for Galia (Ergun et al., 2007), Charentais (Du Chatenet et al., 2000). However, no significant difference among different application temperatures was detected in four melon cultivars.

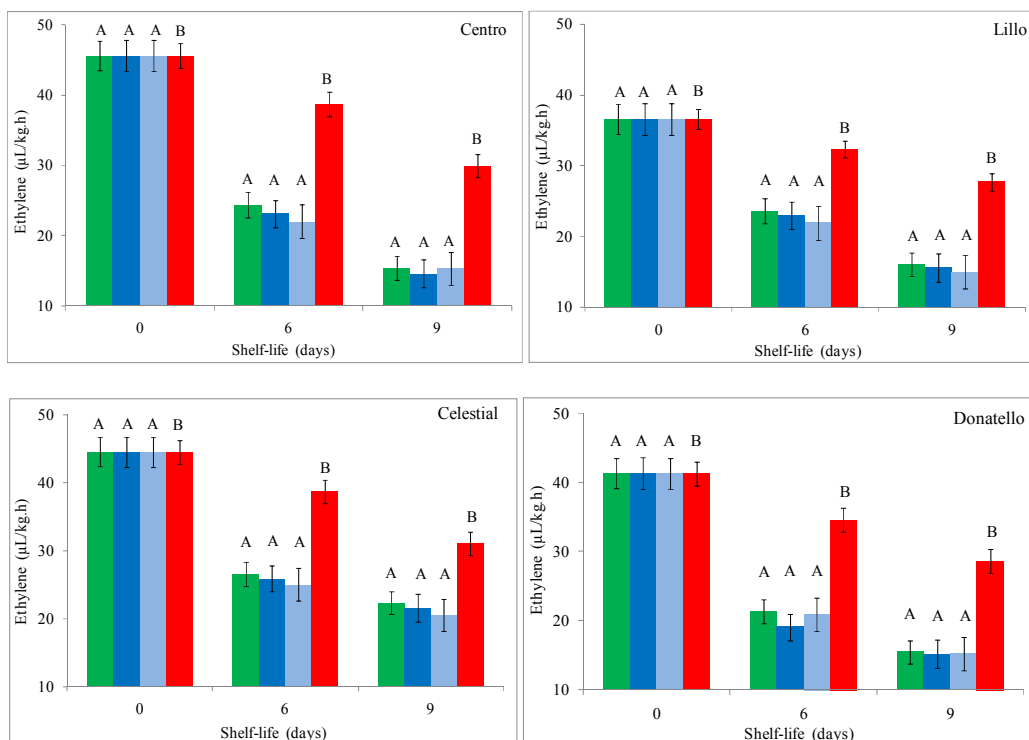

Figure 41. Effect of 1-MCP at different treatment temperatures on ethylene production of four melon cultivars during shelf-life. Presented values are means \pm SD (■ 5 °C, ■ 10 °C, ■ 20 °C, ■ Control). Different letters show significant differences based on treatment temperatures (Tukey's test, $p < 0.05$).

The initial carbon dioxide production was almost the same for the four melon cultivars, around 28 ml kg⁻¹h⁻¹ (Fig. 42). However, during the experiment, the carbon dioxide production of treated Lillo decreased more sharply than that of other cultivars (Fig. 42). There was no difference in respiration among treatment temperatures. 1-MCP treated melon had lower CO₂ production than control. The results also showed that 1-MCP had effect on melon.

The ethylene production and respiration patterns were similar for the four melon cultivars.

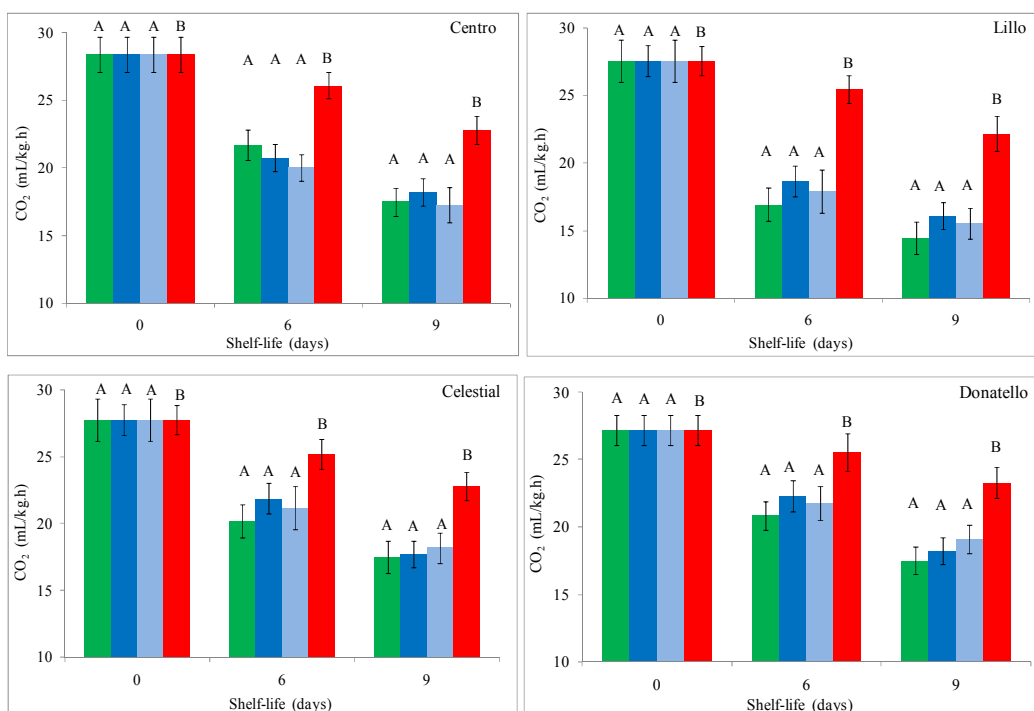

Figure 42. Effect of 1-MCP at different treatment temperatures on respiration of four melon cultivars during shelf-life. Presented values are means \pm SD (■ 5 °C, ■ 10 °C, ■ 20 °C, ■ Control). Different letters show significant differences based on treatment temperatures (Tukey's test, $p < 0.05$).

Acoustic firmness

The acoustic firmness of melons declined throughout shelf-life. The softening of untreated fruits was more rapid than that of treated samples (Fig. 43). It was apparent, that 1-MCP suppressed the softening of melon. The efficiency of 1-MCP in retaining the firmness was also reported for other fruits including tomato (Wills and Ku, 2002), pear (Kubo et al., 2003), apricot and plum (Dong et al., 2002). No significant difference was observed between treatment temperatures in four cultivars.

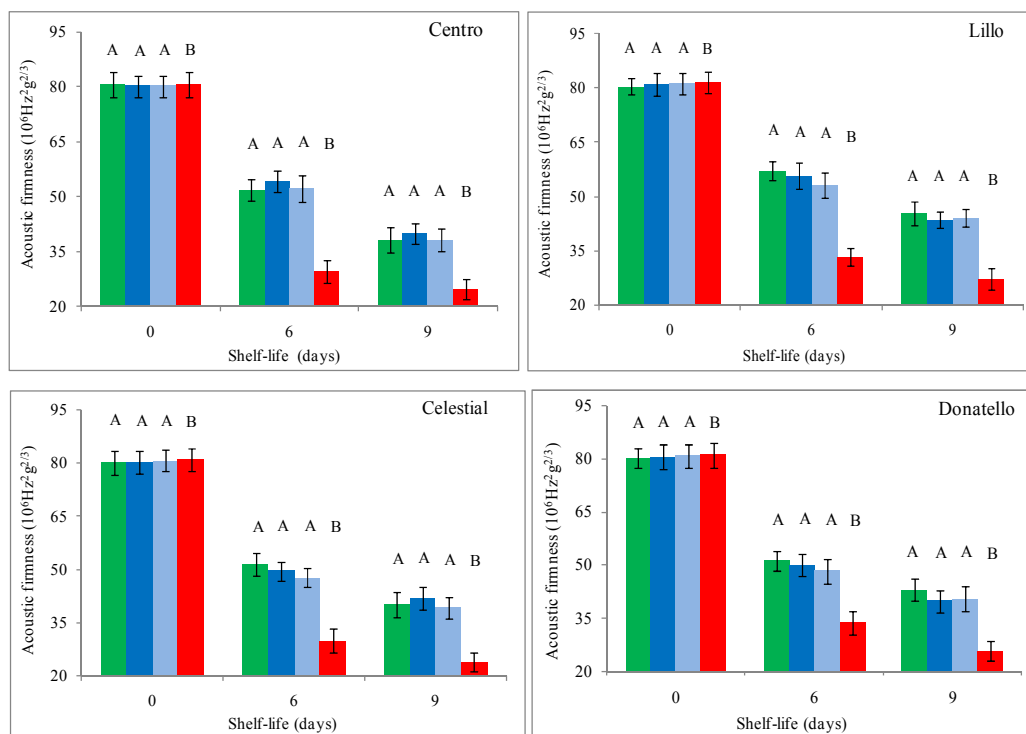

Figure 43. Effect of 1-MCP at different treatment temperatures on acoustic firmness of four melon cultivars during shelf-life. Presented values are means \pm SD (■ 5 °C, ■ 10 °C, ■ 20 °C, ■ Control). Different letters show significant differences based on treatment temperatures (Tukey's test, $p < 0.05$).

Our results were different from a previous report (Perzelan et al., 2014), its finding indicated that application of 1-MCP at 20 °C was more effective in reducing softening of 'Galia' melon than at 5 °C or 10 °C. Most primary studies of 1-MCP application on melon were usually carried out at ambient temperature (Alves et al., 2005; Du Chatenet et al., 2000; Ergun et al., 2007; Gal et al., 2006; Shi et al., 2014). It was said that treatment at cold temperature had less effect than at warm temperature, because the affinity of 1-MCP and receptors was lower at cold temperature (Blankenship and Dole, 2003). Nevertheless, the effects of 1-MCP are dependent on factors such as cultivar, maturity, concentration, temperature and treatment time (Watkins, 2006). A relationship between temperature and time was reported by DeEll et al. (2002). The exposure periods of apples at 3 °C were 9 h, while at higher temperature it required only 6 h (DeEll et al., 2002). Besides, another study showed that treatment at 20 °C for 6 h was as effective as at cold temperature during 24 h (Dauny and Joyce, 2002). 1-MCP application periods of 12-24 h were long enough to obtain a full response (Blankenship and Dole, 2003).

Chlorophyll fluorescence parameters

As shown in Fig. 44, treated melons had higher F_v/F_m value than the control. The results showed that 1-MCP had a pronounced effect on F_v/F_m , however, there was no significant difference in chlorophyll fluorescence parameters among different treatment temperatures throughout shelf-life. At the end of experiment, the controls had the lowest fluorescence parameters F_0 , F_m (data not shown). An earlier research also indicated that 1-MCP could slow the decline in fluorescence parameters of apple during storage (Mir et al., 2001). These results reflected that untreated samples had a rapid loss in chlorophyll content and chloroplast function compared to treated fruits, because the control reached the advancing ripeness and senescence stage. 1-MCP delayed the ripening by occupying ethylene receptors, so that ethylene was unable to elicit its action (Blankenship and Dole, 2003).

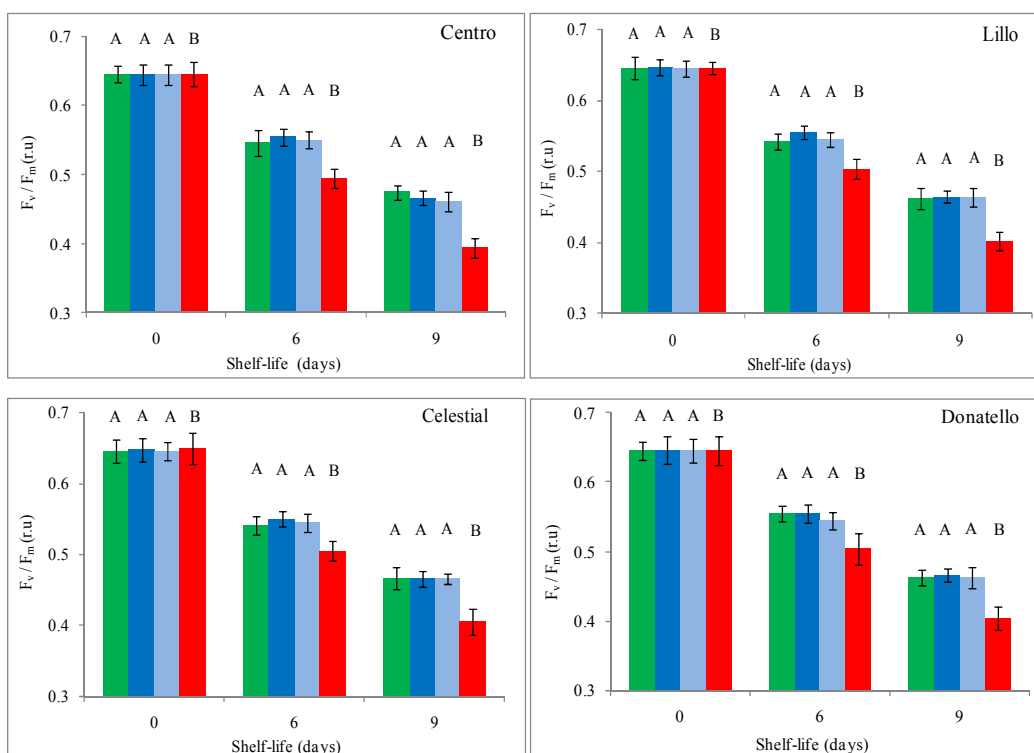

Figure 44. Effect of 1-MCP at different treatment temperatures on F_v/F_m of four melon cultivars during shelf-life. Presented values are means \pm SD (■ 5 °C, ■ 10 °C, ■ 20 °C, ■ Control). Different letters show significant differences based on treatment temperatures (Tukey's test, $p < 0.05$).

Hue angle value

The rind color of all melons turned to yellow during shelf-life. The color change was often a sign of ripening (Dong et al., 2002). The surface color of control fruits changed to yellow more rapidly than that of treated samples. In our study, the effects of different treatment temperatures on respiration, ethylene production, acoustic firmness, chlorophyll fluorescence parameters and surface color were minor or absent for all cultivars.

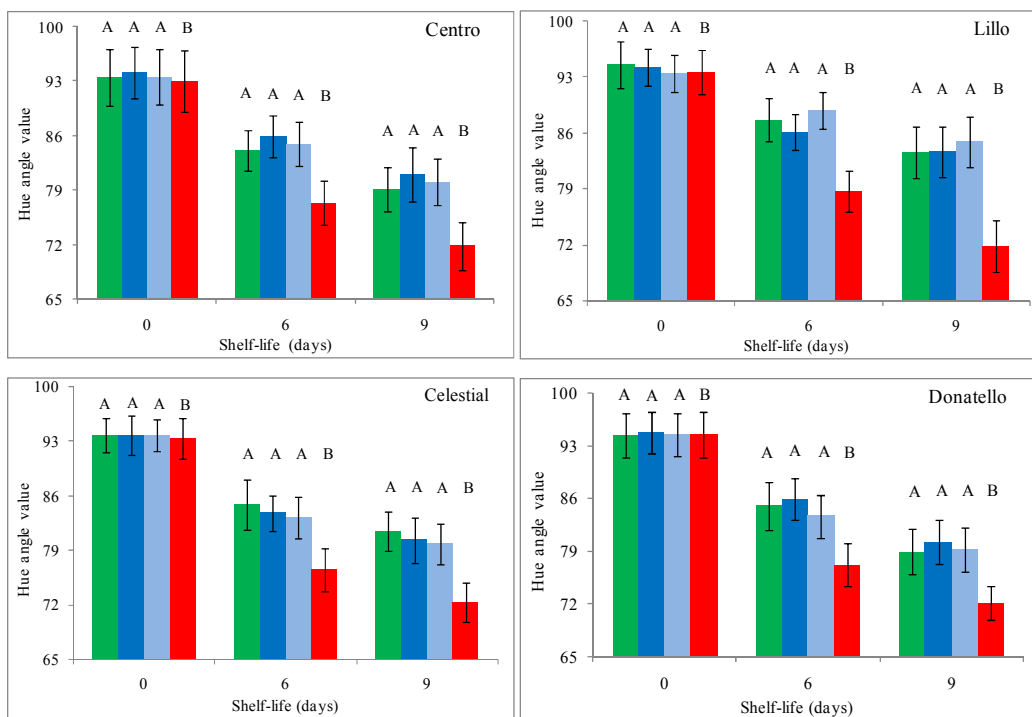

Figure 45. Effect of 1-MCP at different treatment temperatures on hue angle value of four melon cultivars during shelf-life. Presented values are means \pm SD (■ 5 °C, ■ 10 °C, ■ 20 °C, ■ Control). Different letters show significant differences based on treatment temperatures (Tukey's test, $p < 0.05$).

Disease severity

1-MCP did not have effect on disease severity of the four melon cultivars during shelf-life (Table 15). There was no significant difference in decay between control and 1-MCP treated samples on the 3rd, 6th and 9 day of shelf-life at 20 °C. The susceptibility of melons depended on the cultivar. Lillo and Donatello retained better appearance than Celestial and Centro after shelf-life.

Table 15. Disease severity of four melon cultivars during 9 days of shelf-life at 20 °C

Cultivars	Sample	3 rd day	6 th day	9 th day
Lillo	1-MCP _{5°C}	1.0	1.33 a	2.27 a
	1-MCP _{10°C}	1.0	1.40 a	2.33 a
	1-MCP _{20°C}	1.0	1.53 a	2.47 a
	Untreated	1.0	1.60 a	2.53 a
Donatello	1-MCP _{5°C}	1.0	1.33 a	2.33 a
	1-MCP _{10°C}	1.0	1.47 a	2.33 a
	1-MCP _{20°C}	1.0	1.47 a	2.40 a
	Untreated	1.0	1.53 a	2.47 a
Centro	1-MCP _{5°C}	1.0	1.53 a	2.53 a
	1-MCP _{10°C}	1.0	1.60 a	2.60 a
	1-MCP _{20°C}	1.0	1.67 a	2.60 a
	Untreated	1.0	1.90 a	2.70 a
Celestial	1-MCP _{5°C}	1.0	1.53 a	2.53 a
	1-MCP _{10°C}	1.0	1.67 a	2.47 a
	1-MCP _{20°C}	1.0	1.67 a	2.60 a
	Untreated	1.0	1.80 a	2.70 a

1-MCP_{5 °C, 10 °C and 20 °C} : 1-MCP application was carried out at 5, 10 and 20 °C on the 1st day after harvest, respectively

Means followed by the same letters are not significantly different at the same measurement time (Tukey's test, $p < 0.05$).

At the end of experiment, the disease severity was high for all samples. It might be that melon is a ground crop, thus microorganisms present on rind surface could develop rapidly during transport and storage (Bastos et al., 2005). In addition, ambient temperature also favored the microbial growth (Yang et al., 2003).

5.1.2 Effect of different treatment days

This experiment showed that the effects of delayed 1-MCP treatments on the overall quality of four melon cultivars during storage at 10 °C and shelf-life at 20 °C were minor between samples treated on the 1st day and the 3rd day after harvest, but a significant difference between fruits treated on the 1st day and the 5th day after harvest was detected.

Ethylene and CO₂ production

The ethylene production pattern was fairly consistent among four melon cultivars. The ethylene production of both control and 1-MCP treated fruits decreased during whole storage, but at different rates. As shown in Fig. 46, ethylene production of treated fruits was lower than that of the control group throughout storage at 10 °C and subsequent shelf-life.

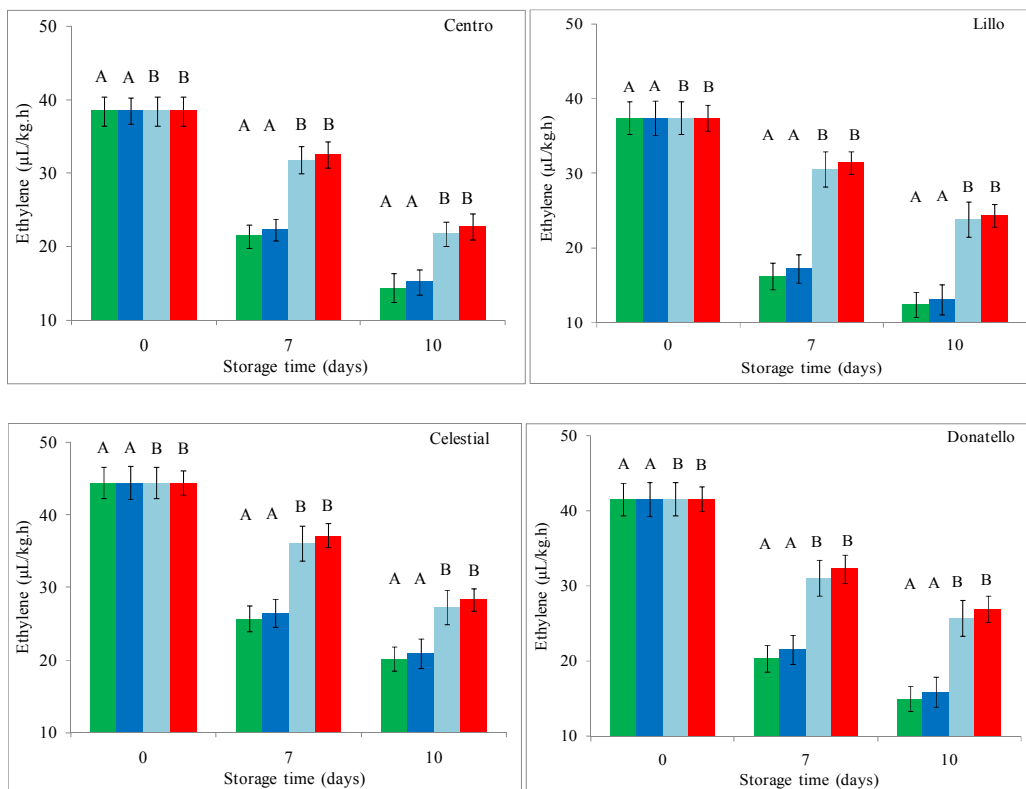

Figure 46. Effect of 1-MCP at different treatment days on ethylene production of four melon cultivars during 7 days of storage at 10 °C and 3 days of shelf-life at 20 °C. Presented values are means \pm SD (■ 1st day; ■ 3rd day; ■ 5th day; ■ Control). Different letters show significant differences based on treatment days (Tukey's test, $p < 0.05$).

These results indicated that 1-MCP treatment on the 1st and 3rd day after harvest was effective in suppressing the ethylene production, in agreement with the previous

report (Alves et al., 2005). Samples treated on the 1st day and 3rd day after harvest were not significantly different in ethylene production. However, application of 1-MCP on the 5th day after harvest had a little effect in reducing ethylene production.

The decline of respiration rate for both control and treated fruits showed a similar trend to ethylene production for the four cultivars (Fig. 47). Also, treated fruits had the lower CO₂ production compared to control. Our results showed that ethylene clearly influenced the postharvest respiration of melons, in coincidence with the results of an earlier study about ‘Galia’ melons (Ergun et al., 2005).

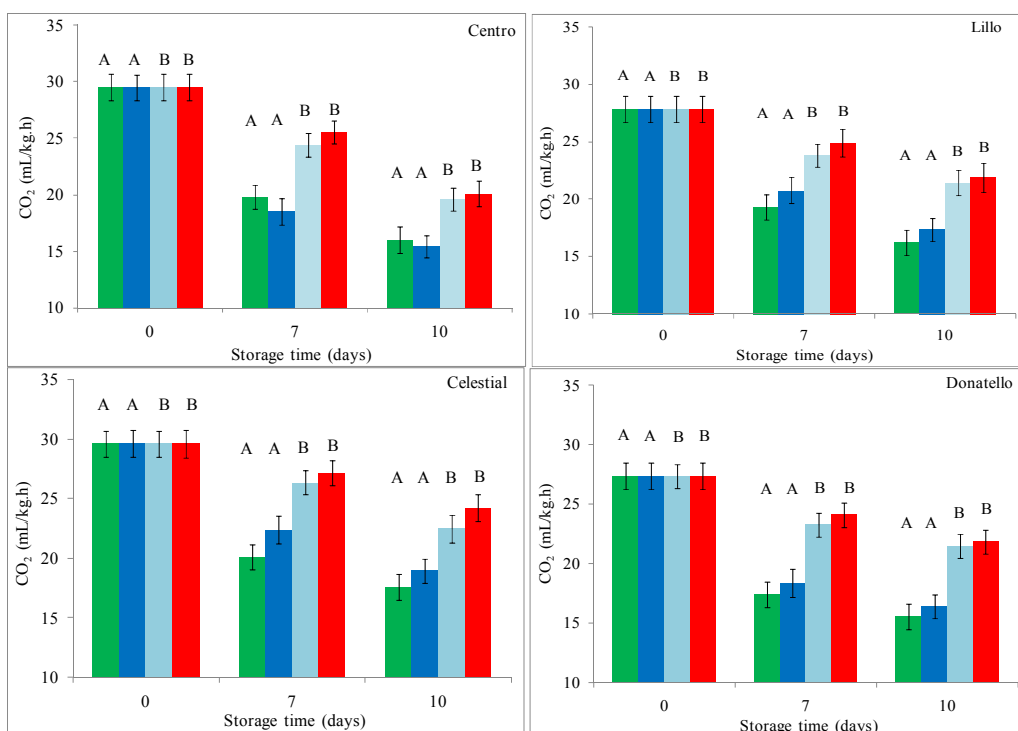

Figure 47. Effect of 1-MCP at different treatment days on CO₂ production of four melon cultivars during 7 days of storage at 10 °C and 3 days of shelf-life at 20 °C. Presented values are means ± SD (■ 1st day; ■ 3rd day; ■ 5th day; ■ Control). Different letters show significant differences based on treatment days (Tukey’s test, $p < 0.05$).

Acoustic firmness

Acoustic firmness of melons decreased throughout storage with similar patterns for four melon cultivars. 1-MCP treatment on the 1st and the 3rd day after harvest delayed the softening of firmness during 7 days of storage at 10 °C and subsequently 3 days of shelf-life, whereas the softening of control samples rose rapidly (Fig. 48). Melons treated on the 1st day after harvest was firmer than others.

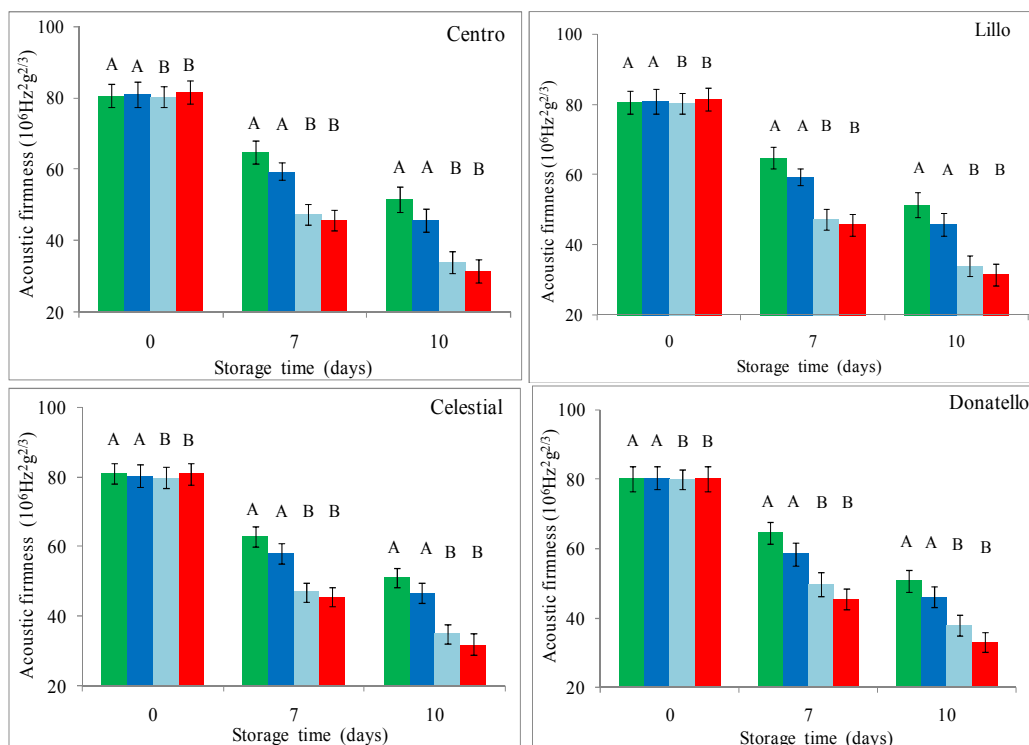

Figure 48. Effect of 1-MCP at different treatment days on firmness of four melon cultivars during 7 days of storage at 10 °C and 3 days of shelf-life at 20 °C. Presented values are means \pm SD (■ 1st day; ■ 3rd day; ■ 5th day; ■ Control). Different letters show significant differences based on treatment days (Tukey's test, $p < 0.05$).

Acoustic firmness of melons treated on the 5th day after harvest was not strongly affected by 1-MCP application. Results also showed that the difference in firmness between fruits treated on the 5th day after harvest and control during whole storage period were only minor (Fig. 48). Less efficacy of 1-MCP at late treatment was perhaps due to incomplete blocking of the ethylene receptors, thus ethylene could exert its action partly in ripening (Blankenship and Dole, 2003; Watkins, 2008). Regarding delayed 1-MCP treatment, previous reports also indicated that the sooner applied treatments increased the possible storage periods (Kubo et al., 2003; Watkins and Nock, 2005).

Chlorophyll fluorescence parameters

Chlorophyll fluorescence parameters decreased during storage (Fig. 49). As shown in Fig. 49, the values of F_v/F_m of control samples decreased rapidly after 7 days of storage at 10 °C and continually had a sharp decline throughout shelf-life. In addition, the chlorophyll fluorescence parameters F_0 and F_m of fruits treated on the 1st and 3rd day was significantly higher than that of samples treated on the 5th day after harvest and control (data not shown). The change of F_v/F_m is also related to the ethylene

action on postharvest life of fruit (Mir et al., 2001). Ethylene plays an important role in the ripening process. 1-MCP inhibited the ripening by occupying ethylene receptors, so that ethylene is unable to elicit its action (Blankenship and Dole, 2003). Similar results were found for apple and banana (Blackbourn et al., 1990; Mir et al., 2001).

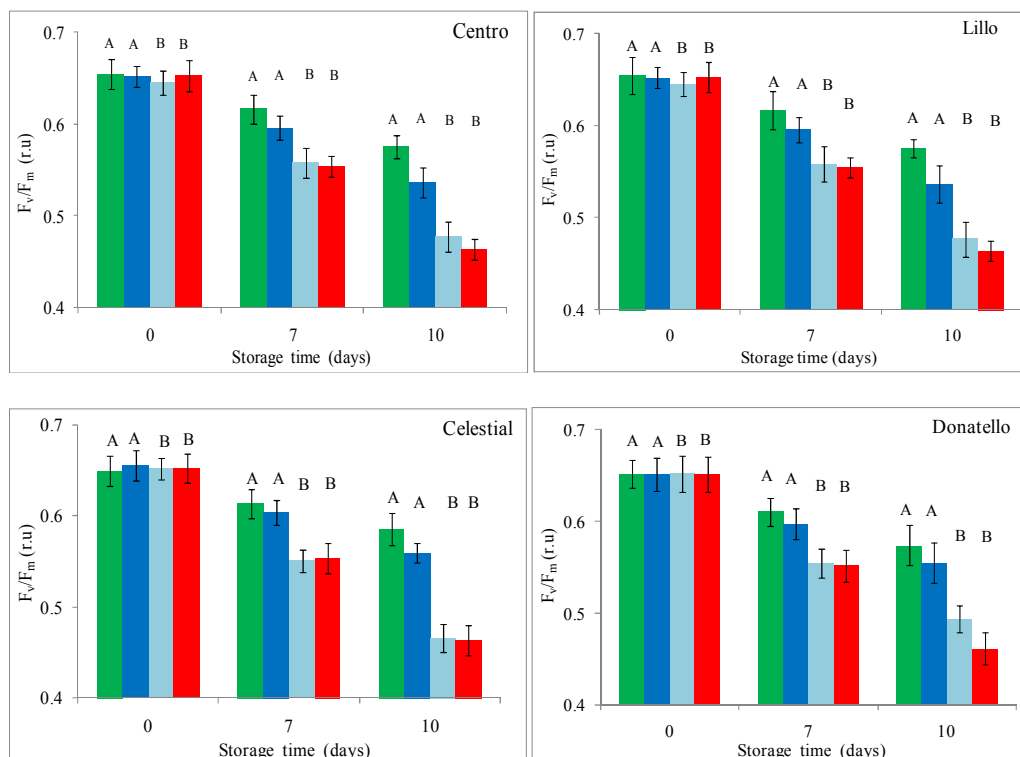

Figure 49. Effect of 1-MCP at different treatment days on chlorophyll fluorescence parameter (F_v/F_m) of four melon cultivars during 7 days of storage at 10 °C and 3 days of shelf-life at 20 °C. Presented values are means \pm SD (■ 1st day; ■ 3rd day; ■ 5th day; ■ Control). Different letters show significant differences based on treatment days (Tukey's test, $p < 0.05$).

Hue angle value

The color development of melon surface was expressed by hue angle values. Hue angle values of four melon cultivars decreased throughout the whole storage period due to ripening (Fig. 50). The efficacy of 1-MCP in inhibiting the ripening process of melons was also confirmed by slowing the color change.

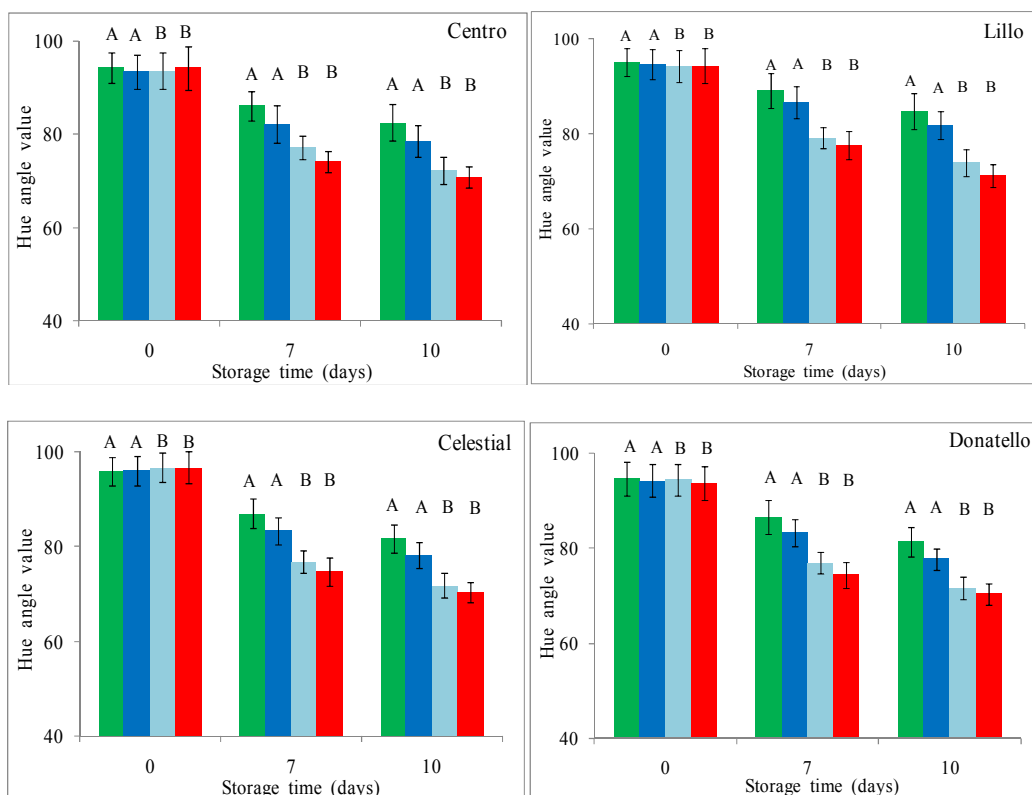

Figure 50. Effect of 1-MCP at different treatment days on hue angle values of four melon cultivars during 7 days of storage at 10 °C and 3 days of shelf-life at 20 °C. Presented values are means \pm SD (■ 1st day; ■ 3rd day; ■ 5th day; ■ Control). Different letters show significant differences based on treatment days (Tukey's test, $p < 0.05$).

Melon peel lost its greenness and additionally, its yellowness increased during the storage period. Other fruits, including apple and papaya also showed similar results (Bron et al., 2004; Song et al., 1997). The similar trends of peel color change were observed for four cultivars. The rind of control fruit was more dark yellow than those of other treatments after shelf-life, coincided with the previous report for 'Galia' melon (Ergun et al., 2005) and banana (Pongprasert and Srilaong, 2014). In this experiment, 1-MCP application could be delayed till the 3rd day after harvest, whereas treatment on the 5th day after harvest was too late to control the postharvest ripening of melon.

Disease severity

Disease severity increased during storage period for all samples. No chilling injury symptoms were detected for four cultivars throughout cold storage at 10 °C. In this experiment, 1-MCP did not have benefit in decreasing decay incidence of four melon cultivars (Table 16) that was similar to experiment in part 5.1.1. Treated fruits were less disease than control at the 7th day and 10th day of storage, but the difference

was not significant in this case (Table 16). Rot is also one of the main problems during postharvest transport and storage melon (Fallik et al., 2000; Mayberry and Hartz, 1992). As shown in table 16, fruits were more susceptible to disease at the end of experiment due to aging and senescence. In addition, ambient temperature during shelf-life also favored the microbial growth (Miccolis and Saltveit, 1995; Yang et al., 2003). The sensitivity of melon to decay depended on cultivar. The four cultivars were separated into two distinct groups regarding susceptibility to rot throughout postharvest storage. Lillo and Donatello retained better appearance after shelf-life, whereas Celestial and Centro were vulnerable to deterioration.

Table 16. Disease severity of four melon cultivars during 7 days of storage at 10 °C and 3 days of shelf-life at 20 °C

Cultivars	Sample	4 th day	7 th day	10 th day
Lillo	1-MCP _{1st}	1.0	1.33 a	2.27 a
	1-MCP _{3rd}	1.0	1.40 a	2.33 a
	1-MCP _{5th}	1.0	1.53 a	2.40 a
	Untreated	1.0	1.60 a	2.47 a
Donatello	1-MCP _{1st}	1.0	1.33 a	2.33 a
	1-MCP _{3rd}	1.0	1.47 a	2.33 a
	1-MCP _{5th}	1.0	1.47 a	2.40 a
	Untreated	1.0	1.53 a	2.47 a
Centro	1-MCP _{1st}	1.0	1.53 a	2.53 a
	1-MCP _{3rd}	1.0	1.60 a	2.53 a
	1-MCP _{5th}	1.0	1.67 a	2.60 a
	Untreated	1.0	1.90 a	2.70 a
Celestial	1-MCP _{1st}	1.0	1.53 a	2.53 a
	1-MCP _{3rd}	1.0	1.67 a	2.60 a
	1-MCP _{5th}	1.0	1.67 a	2.53 a
	Untreated	1.0	1.80 a	2.70 a

1-MCP_{1st, 3rd and 5th} : 1-MCP application was carried out at day 1, 3 and 5 after harvest, respectively

Means followed by the same letters are not significantly different at the same measurement time (Tukey's test, $p < 0.05$).

5.1.3 Effect of 1-MCP microbubbles (1-MCP MBs) treatment

Ethylene and CO₂ production

This work showed that 1-MCP MBs affected the quality of melons during shelf-life in comparison to control. The efficacy of 1-MCP MBs increased with longer treatment time. Results indicated that the ethylene production of control and fruits treated with 1-MCP MBs for 15 min rose rapidly to the peak after 3 days of shelf-life at 20 °C, whereas samples receiving other treatments had a gradually increase within the first 6 days (Fig. 51A) of shelf-life.

Similarly, CO₂ production of control and samples treated with 1-MCP MBs for 15 min reached maxima at day 6th of shelf-life (Fig. 51B). As shown in Fig. 51, longer 1-MCP MBs treatment and conventional application suppressed the respiration during 9 days of shelf-life at 20 °C. The ethylene production and respiration of fruits treated with 1-MCP MBs for 15 min was lower than control, but it was not a significant difference (Fig. 51) according to the statistical analysis.

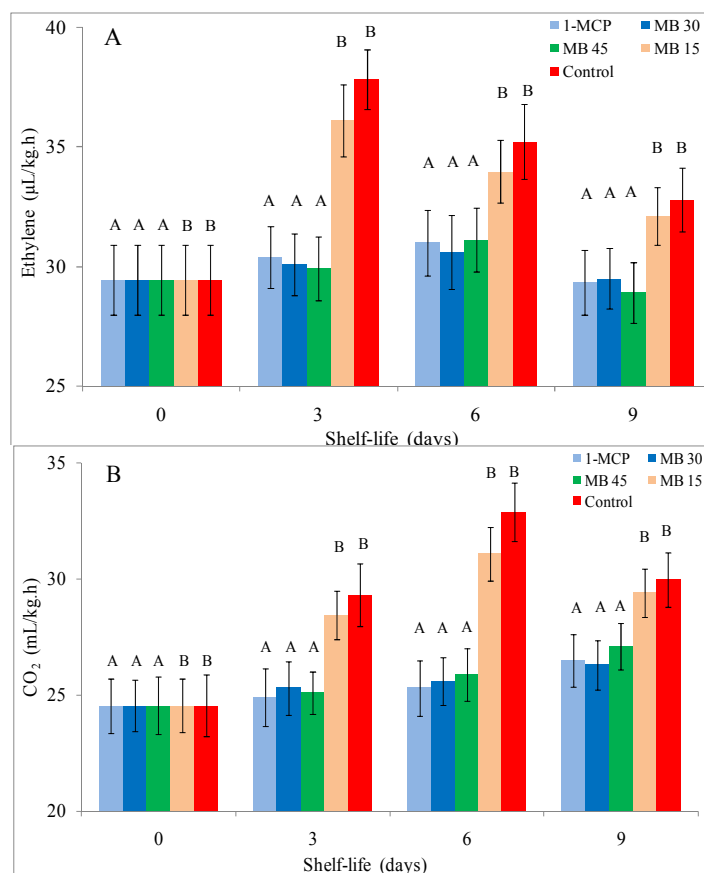

Figure 51. Ethylene (A) and CO₂ (B) production of melon during 9 days of shelf-life at 20 °C. Values are the mean ± SD (■ 1-MCP MBs 45 min; ■ 1-MCP MBs 30 min; ■ gaseous 1-MCP; ■ 1-MCP MBs 15 min; ■ Control). Different letters show significant differences based on treatments (Tukey's test, $p < 0.05$).

In contrast, 1-MCP MBs application for 30 and 45 min strongly affected the inhibition of the ethylene and CO₂ production of melons during shelf-life compared to control. These results indicated that 1-MCP gaseous form and 1-MCP MBs 30 and 45 min had the same efficacy.

Acoustic firmness

Firmness values of all samples were presented in Fig. 52. The effect of treatment on firmness was notable for conventional 1-MCP and 1-MCP MBs for 30 min and 45 min. As shown in Fig. 52, 1-MCP could delay the fruit softening, but at different rates, whereas control samples softened quickly during shelf-life. Immersion in aqueous 1-MCP MBs for 30 min, 45 min or exposure to gaseous 1-MCP resulted in slowing the softening of melon. Meanwhile, fruits treated with 1-MCP MBs for 15 min had a sharp decline in firmness.

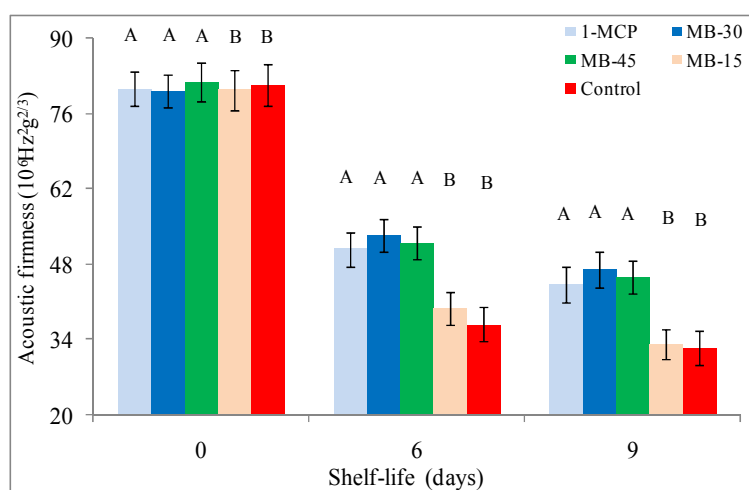

Figure 52. Acoustic firmness of melon during 9 days of shelf-life at 20 °C. Values are the mean \pm SD (■ 1-MCP MBs 45 min; ■ 1-MCP MBs 30 min; ■ gaseous 1-MCP; ■ 1-MCP MBs 15 min; ■ Control). Different letters show significant differences based on treatments (Tukey's test, $p < 0.05$).

Hue angle value and chlorophyll fluorescence parameters

The influences of 1-MCP on delaying the postharvest ripening were also more pronounced by slowing the skin color change of melon. Hue angle value of control fruit decreased drastically throughout storage period (Fig. 53A). In contrast, fruits treated with conventional 1-MCP and 1-MCP MBs for 30 or 45 min had a progressive decline in hue angle values. The peel of control fruits turned more orange than that of 1-MCP treated melons. Moreover, chlorophyll fluorescence parameters also showed the correlation with skin color development (Fig. 53). Surface color changed somewhat

parallel to chlorophyll degradation. However, there was only a minor difference between control and 1-MCP MBs 15 min treatment. Fruits treated with gaseous 1-MCP and 1-MCP MBs 30, 45 min remained higher values in F_v/F_m and hue angle value compared to control.

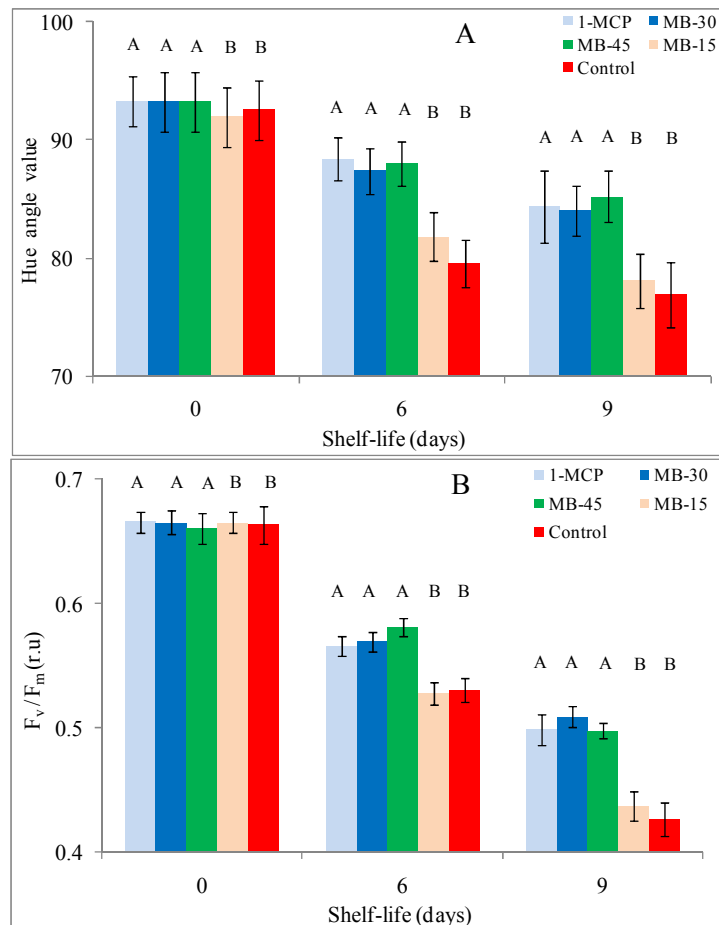

Figure 53. Hue angle value (A) and F_v/F_m (B) of melon during 9 days of shelf-life at 20 °C. Values are the mean \pm SD (■ 1-MCP MBs 45 min; ■ 1-MCP MBs 30 min; ■ gaseous 1-MCP; ■ 1-MCP MBs 15 min; ■ Control). Different letters show significant differences based on treatments (Tukey's test, $p < 0.05$).

It was apparent, 1-MCP MBs had similar benefit to conventional 1-MCP in delaying postharvest ripening of melon. However, 1-MCP MBs application for 15 min was found to be not effective in suppressing the ethylene and CO_2 production as well as slowing the softening and peel color change. This could be explained by that 15 min 1-MCP MBs treatment is not long enough to deliver 1-MCP to plant tissue. Treatment time is also an important factor in 1-MCP application (Sozzi and Beaudry, 2007).

The efficacy of gaseous 1-MCP in delaying the ripening of melon has been extensively reported, 1-MCP treated melons were better quality than control fruits (Bai

et al., 2014; Ergun et al., 2005; Du Chatenet et al., 2000; Lima et al., 2004; Shi et al., 2014). Other study also indicated that 1-MCP could double the shelf-life of cantaloupe melons at ambient temperature (Alves et al., 2005). However, gaseous 1-MCP application requires long treatment time and air tight storage room (Blankenship and Dole, 2003). These requirements sometimes make conventional 1-MCP application limited to utilize widely in commercial level (Pongprasert and Srilaong, 2014). Recently, there have been many research about 1-MCP aqueous form for apple (Argenta et al., 2007), tomato and avocado (Choi et al., 2008; Zhang et al., 2009; Zhang et al., 2011). 1-MCP in water was found as effective as gaseous 1-MCP in extending storage period with only 4 minutes long treatment, however, the concentration required was about 700 fold higher than 1-MCP in air (Argenta et al., 2007). Therefore, the application of the conventional 1-MCP is much more economic than aqueous 1-MCP application based on the necessary amount to attain the similar physiological response (Argenta et al., 2007; Zhang et al., 2009). In our work, both conventional 1-MCP and 1-MCP MBs treatment for 30 or 45 min had the similar benefit in delaying the ripening of melon.

Recent years, MBs have drawn attention because of important characteristics such as negative surface charge and shrinkage in water (Zimmerman et al., 2011). Residing in water for a long time compared to macrobubbles rising rapidly and bursting at surface, makes MBs to deliver gas into a solution effectively (Zimmerman et al., 2011). In addition, it has been found that MBs - having a large surface area - could dissolve and disperse gas efficiently, therefore stimulated lettuce root growth and agal growth (Park and Kurata, 2009; Zimmerman et al., 2011). In our study, 1-MCP MBs had efficacy in extending shelf-life of melons, this could be explained that 1-MCP MBs carrying gaseous 1-MCP dispersed and dissolved 1-MCP effectively. In addition, numerous 1-MCP MBs attached to melon surface and then delivered 1-MCP to plant tissue.

Disease severity

Moulds developed on the melon surface during shelf-life, however, the sign of decay appeared earlier in control fruits compared to 1-MCP treated samples (Fig. 54). Control fruits had the highest incidence of rots throughout shelf-life compared to other treatments, but no significant difference was detected.

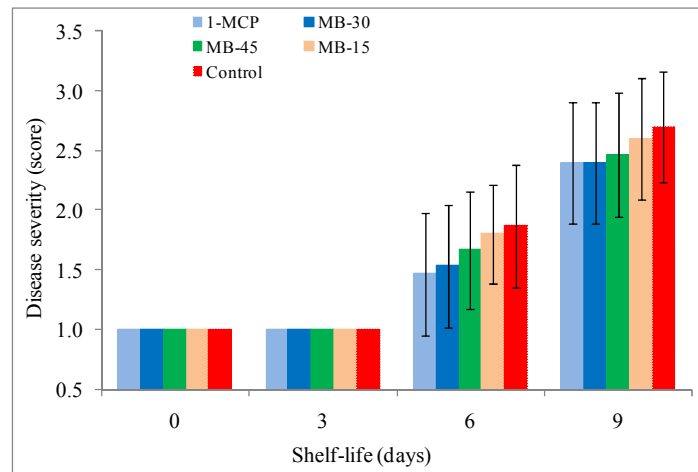

Figure 54. Disease severity of melon during 9 days of shelf-life at 20 °C. Values are the mean \pm SD (■ 1-MCP MBs 45 min; ■ 1-MCP MBs 30 min; ■ gaseous 1-MCP; ■ 1-MCP MBs 15 min; ■ Control).

Disease severity was high in both control and 1-MCP treated fruits, which may be due to melon being a ground crop, thus microorganisms were available originally on the surface and developed rapidly during storage (Fallik et al., 2000). This problem would be considered in next parts (5.2 and 5.3).

5.2 Effect of 1-MCP, ethylene absorber and ozone treatment

Ethylene and CO₂ production

As shown in Fig. 55, the ethylene production of fruits treated with 1-MCP was significantly lower than others. Samples treated without 1-MCP showed high ethylene production persisting during whole storage. Ethylene absorber (EA) or ozone alone did not show benefit in declining ethylene production compared to control (Fig. 55A). In addition, the combination of 1-MCP and EA or ozone did not have any additional advantages in comparison with 1-MCP. Similarly, 1-MCP application also influenced CO₂ production more strongly than that of other treatments (Fig. 55B). No difference was detected in respiration rates between control, and fruits treated with EA or ozone.

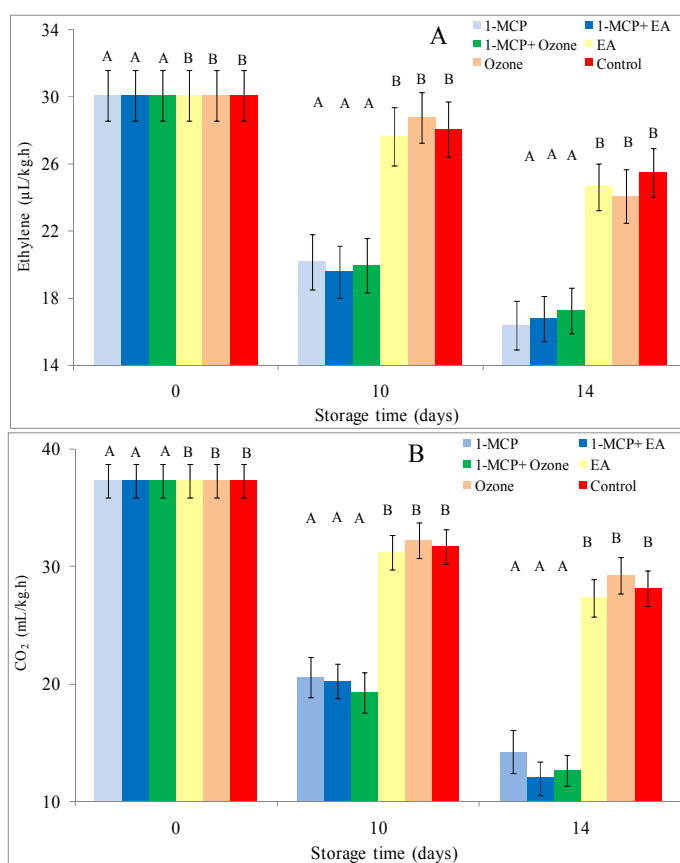

Figure 55. Ethylene (A) and CO₂ (B) production of melon during 10 days of storage at 5 °C and 4 days of shelf-life at 20 °C. Values are the mean ± SD (■ 1-MCP and Ozone; ■ 1-MCP and EA; ■ 1-MCP; ■ Ozone; ■ Control; ■ EA). Different letters show significant differences based on treatments (Tukey's test, $p < 0.05$).

Acoustic firmness and hue angle value

Acoustic firmness and hue angle values of all samples declined with increasing storage period, but at different rates (Fig. 56). Firmness of all samples exhibited a sharp decrease throughout shelf-life due to higher temperature. Another reason could be that fruits were close to advanced ripening. According to these differences, there were two distinct groups: 1-MCP treated samples retained firmness and surface color rather than that of control, EA or ozone treated fruits. Application of 1-MCP dramatically inhibited ethylene action inducing the ripening of melon. Consequently, fruits derived from 1-MCP treatment had higher firmness and hue angle values compared to others during experiment (Fig. 56). In contrast, the presence of EA or ozone did not affect significantly firmness and hue angle values vs. control during cold storage and shelf-life (Fig. 56).

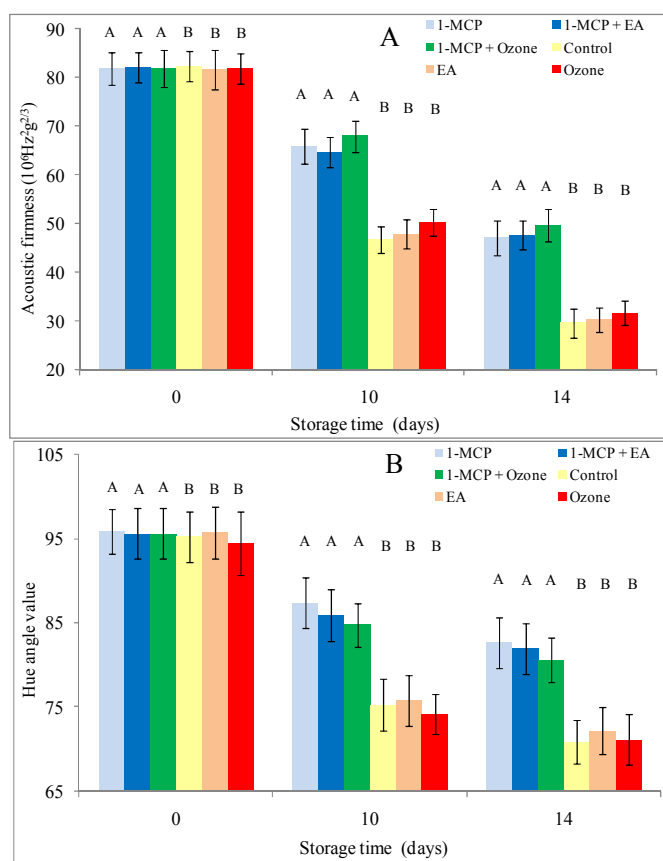

Figure 56. Acoustic firmness (A) and hue angle value (B) of melon during 10 days of storage at 5 °C and 4 days of shelf-life at 20 °C. Values are the mean \pm SD (■ 1-MCP and Ozone; ■ 1-MCP and EA; ■ 1-MCP; ■ Ozone; ■ Control; ■ EA). Different letters show significant differences based on treatments (Tukey's test, $p < 0.05$).

Samples treated with EA or ozone were firmer than control, but only slightly. Also, the chlorophyll fluorescence parameters didn't show difference between control and EA or ozone treated fruits (data not shown). In addition, fruits previously stored with EA or ozone still continued normal ripening during shelf-life, similarly to control. On the contrary, 1-MCP still delayed the ripening throughout shelf-life.

1-MCP delayed the ripening of melon, could maintain melon quality during 10 days at cold storage and 4 days of shelf-life compared to other treatments. This was coincident with previously reported results (Ergun et al., 2005; Gal et al., 2006; Shi et al., 2014). Ethylene absorber decreased fruit softening, but not significantly compared to control. Ethylene absorber and 1-MCP have been used widely to control ethylene action, in order to delay ripening during the transport and storage, however, each of them has its different impact. In case of 1-MCP treatment, perception of ethylene was blocked, while ethylene removal decreased ethylene level in the storage environment, particularly in sealed environment such as controlled atmosphere and packaging (Terry et al., 2007; Watkins, 2006). It is assumed that 1-MCP binds irreversibly the ethylene receptors (Meyer and Terry, 2010), therefore, 1-MCP could maintain the effect during the whole storage. While ethylene absorber could not have effect when samples were removed from chamber, fruits resume normal ripening when removed from ethylene absorber (Meyer and Terry, 2010; Silva et al., 2009). In this work, melon treated with 1-MCP did not fully ripen, in agreement with an earlier report for avocado (Meyer and Terry, 2010). The combination of 1-MCP and ethylene absorber did not have any additional effect in comparison to 1-MCP alone.

Number of studies reported that ozone treatment had effectiveness in extending shelf-life of persimmon (Salvador et al., 2006), papaya (Ali et al., 2014), broccoli and cucumber (Skog and Chu, 2001). However, there was no effect of ozone treatment on apple and pear (Skog and Chu, 2001). Thus, ozone efficacy might depend on produce (Liew and Prange, 1994). In this work, samples treated with ozone or EA alone did not have effect in maintaining acoustic firmness and surface color.

Chilling injury

There was no significant difference in sensitivity to CI between treatments during the first 8 days of storage (Table 17). Storing at 5 °C induced CI on melon skin. CI developed approximately 10 % of the melon rind surface area on the 4th day of cold storage and increased with extending cold storage period. Samples stored with ozone were more sensitive to CI than other samples, however, the significant difference was only observed on the 10th day of storage and shelf-life.

Table 17. Chilling injury rating of melon during 10 days of storage at 5 °C and 4 days of shelf-life at 20 °C

Day \ Treatments	0	4 th	8 th	10 th	14 th
1-MCP	1.0	1.8 a	2.1 a	2.1 a	2.1 a
1-MCP + EA	1.0	1.9 a	2.1 a	2.1 a	2.1 a
1-MCP + ozone	1.0	1.9 a	2.4 a	2.5 b	2.5 b
EA	1.0	1.9 a	2.1 a	2.1 a	2.1 a
Ozone	1.0	2.1 a	2.4 a	2.5 b	2.5 b
Control	1.0	1.9 a	2.1 a	2.1 a	2.1 a

Means followed by the same letters are not significantly different at the same measurement time (Tukey's test, $p < 0.05$).

Ozone treatment had higher CI rates perhaps due to cuticle damage caused by the oxidizing activity of ozone (Ali et al., 2014; Salvador et al., 2006). Therefore, skin was more susceptible to low temperature.

Disease severity

The early sign of microbial decay occurred on the 8th day of cold storage and developed rapidly during shelf-life (Table 18). Low temperature could slow the microbial growth. Ozone was effective in inhibiting microbial development during storage at 5 °C, however, fruits previously stored with ozone had serious decay during shelf-life. 1-MCP treated samples had less decay than others. That was different from earlier results shown in part 5.1. It could be that 1-MCP and low temperature had a synergistic benefit in controlling main problems of melon. However, the differences in decay only occurred after 8 days of storage.

There was no significant difference in disease severity between fruits treated with EA, ozone or control throughout shelf-life. Probably control and EA treated fruits were at advanced ripening stage, thus more susceptible to decay.

Table 18. Disease severity of melon during 10 days of storage at 5 °C and 4 days of shelf-life at 20 °C

Day \ Treatments	0	4 th	8 th	10 th	12 th	14 th
1-MCP	1.0	1.0	1.1a	1.1 a	1.3 a	1.7 a
1-MCP + EA	1.0	1.0	1.1 a	1.1 a	1.4 a	1.9 a
1-MCP + ozone	1.0	1.0	1.0 a	1.0 a	1.7 ab	2.5 b
EA	1.0	1.0	1.1 a	1.3 ab	1.5 ab	2.5 b
Ozone	1.0	1.0	1.0 a	1.0 a	1.7 ab	2.7 b
Control	1.0	1.0	1.3 a	1.5 b	1.7 ab	2.5 b

Means followed by the same letters are not significantly different at the same measurement time (Tukey's test, $p < 0.05$).

Fruits stored with ozone showed less disease severity than those of other treatments during cold storage due to antimicrobial efficacy of ozone (Guzel-Seydim et al., 2004). The result coincided with previous reports (Palou et al., 2002). Nonetheless, in this work melons exposed to ozone prior to shelf-life had more serious decay throughout shelf-life than the rest, because a cleaner surface may be more susceptible to recontamination (Gil et al., 2009; Ukuku, 2006).

5.3 Effect of washing treatments on mesophilic aerobes

Population of mesophilic aerobes after treatment

The efficacy of treatments in the reduction of the mesophilic aerobes was shown in Fig. 57. All treatments had an effect on microorganism populations, but at different rates. These results indicated that ozone MBs 5 min and hot water MBs were the most effective in reducing microbial loads. Washing with ozone MBs for 5 min and hot water MBs for 2 or 5 min decreased approximately 2.3, 2 and 1.7 log cfu/cm², respectively, compared to control. Although, ozone MBs treatment for 2 min was less efficient than for 5 min, however, there were smaller mesophilic populations on rind surface of melon treated with ozone MBs for 2 min than that of the rest (Fig. 57). Hot water and chlorine alone or chlorine MBs could decrease the load with about 1 log cfu/cm². Tap water had no effect compared to control. No sign of damage on melon rind surface was detected after treatments.

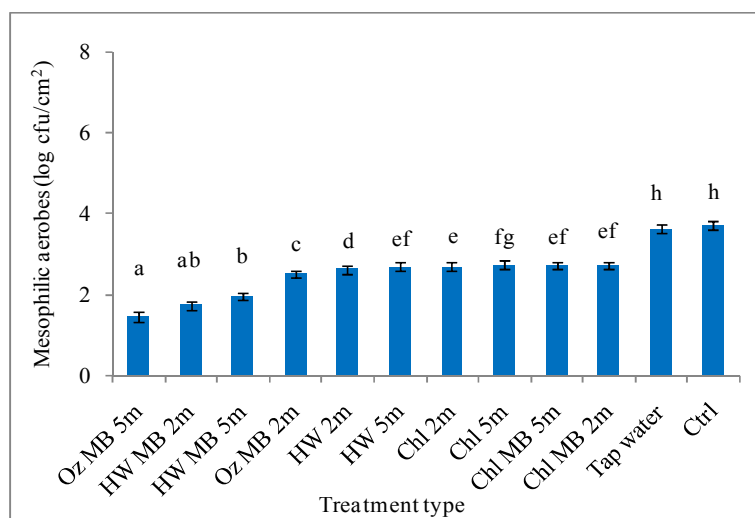

Figure 57. Population of mesophilic aerobes on melon rind surface after treatment. Values are the mean \pm SD. Different letters show significant differences based on treatments (Tukey's test, $p < 0.05$).

In this study, ozone MBs had benefit in reducing mesophilic aerobes due to oxidation property of ozone. In addition, free radical generated by collapsing MBs improved sanitizing ability of ozone MBs (Agarwal et al., 2011; Sumikura et al., 2007; Takahashi et al., 2007). Ozone attacks microbial cell surface, firstly reacts with sulfhydryl groups, peptides, proteins and then polyunsaturated fatty acid leading leakage of cellular compositions. Ozone oxidizes the essential components of cellular microorganism causing cell death (Victorin, 1992). These results showed that ozone MBs for 2 min was less effective than that of 5 min because treatment for 2 min may be

not long enough to disinfect melon rind surface. In our work, ozone MBs was much more effective than chlorine, because ozone is the second strongest oxidant, more powerful than chlorine (Guzel-Seydim et al., 2004). Moreover, ozone damages most of the proteins inside microbial cells, whereas chlorine selectively oxidizes internal cellular enzymes (Kim et al., 1999).

Hot water MBs achieved a high reduction of mesophilic aerobes than hot water alone due to generation of free radical by collapsing MBs. In this experiment, chlorine was less efficient than hot water. It could be explained that the contact between chlorine and microorganism was not good enough due to roughness and waxiness of melon rind (Bastos et al., 2005).

Population of mesophilic aerobes, and decay after shelf-life

There were significant differences in mesophilic aerobes on melon surface among treatments after 4 days of shelf-life (Fig. 58). Melons treated with ozone MBs for 5 min or hot water MBs had the lowest microbial loads, followed by that of ozone MBs 2 min, chlorine alone or chlorine MBs, and hot water. The number of microorganisms on melon washed with tap water was close to that of control samples. Chlorine was more effective in controlling microbial loads on melon surface than hot water treatment on the 4th day of shelf-life at 20 °C.

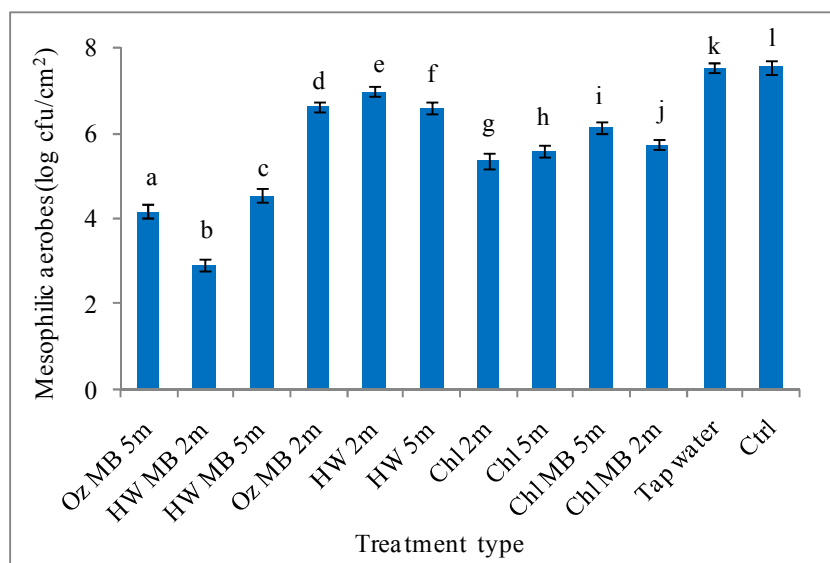

Figure 58. Population of mesophilic aerobes on melon rind surface after 4 days of shelf-life. Values are the mean \pm SD. Different letters show significant differences based on treatments (Tukey's test, $p < 0.05$).

Untreated or tap water washed melon had highest disease incidence and severity than others (Table 19). After 4 days of shelf-life, the decay percentage of samples treated with hot water MBs and ozone MBs for 5 min were around one third, less than other treatments (Table 19). In addition, appearance of these treatments was still acceptable. Ozone MBs for 2 min was less effective than ozone MBs for 5 min and hot water MBs, but better than the rest. The disease incidence was above 50 % in case of hot water, chlorine alone or chlorine MBs treatment and the appearance was almost unacceptable.

Table 19. Disease incidence and disease severity after 4 days of shelf-life at 20 °C

Washing treatment	Disease incidence (%)	Disease severity
Control	83.3 e	2.8 c
Tap water	76.7 cde	2.7 bc
Hot water 2 min	63.3 cd	2.3 a
Hot water 5 min	63.3 cd	2.3 a
Hot water + MBs 2 min	33.3 a	1.6 abc
Hot water + MBs 5 min	36.7 a	1.7 abc
Chlorinated water 2 min	60.0 bcd	2.5 abc
Chlorinated water 5 min	56.7 bc	2.3 abc
Chlorine + MBs 2 min	60.0 bcd	2.5 abc
Chlorine + MBs 5 min	66.7 cde	2.4 abc
Ozone microbubbles 2 min	43.3 ab	2.4 abc
Ozone microbubbles 5 min	36.7 a	1.8 ab

Means followed by the same letters are not significantly different at the same measurement time (Tukey's test, $p < 0.05$).

Samples treated with ozone MBs 5 min and hot water MBs had the lowest mesophilic populations and disease incidence after shelf-life due to the low level of initial values. In addition, it might be, that microorganisms need time to recovery after stress (Gil et al., 2009). Chlorine controlled microbial populations during shelf-life more effectively than hot water or ozone MBs 2 min due to chlorine residues on melon surface. Another reason was that cleaner melons may be more susceptible to recontamination in poor hygiene environment (Ukuku, 2006). It is worth to notice, that an effective sanitizing method cannot continually have effect during storage without good hygiene.

6. NEW SCIENTIFIC RESULTS

This study was carried out in order to evaluate the impact of 1-MCP treatment, storage condition and washing methods on postharvest life of melon. Data were collected during two seasons from 2014 to 2015 in, Hungary. The results indicated some important findings as follows.

1. It was concluded, that 1-MCP application time could be delayed till the 3rd day after harvest, when melons were kept at 10 °C before treatment. Response of four melon cultivars (Lillo, Centro, Celestial and Donatello) during shelf-life indicated that the effectiveness of 1-MCP decreased significantly with late treatment (5th day after harvest). Significant difference was observed between fruits treated at 1st and 5th day after harvest ($p < 0.05$).
2. Application of gaseous 1-MCP on the 1st day after harvest was able to extend the shelf-life of melon till 9 days at storage temperature of 20 °C. Ethylene and CO₂ production of Centro cultivar after 9 days shelf-life decreased to 48 % and 24 %, respectively, compared to control. Four investigated melon cultivars had similar patterns of quality changes.
3. It was concluded, that 1-MCP microbubbles treatment for at least 30 min was able to delay ripening of ‘Donatello’ melon during 9 days of shelf-life. Ethylene and CO₂ production of ‘Donatello’ melon, treated for 30 min, obtained approximately 11% and 12% lower values, respectively, compared to control.
4. Ozone treatment at 0.1 ppm/h proved to be effective in inhibiting microbial development on ‘Donatello’ melon during storage at 5 °C for 10 days, but fungal growth became serious after removal of fruits for shelf-life at 20 °C.
5. Ozone microbubbles treatment for 5 min, with the concentration of 150 ppm, had benefit in disinfection melon rind. The ozone microbubbles treatment using water of 16 °C and pH =7-8 for 5 min reached significant reduction in the mesophilic aerobes of 2.3 log₁₀cfu.
6. Hot water microbubbles treatment was proved to be efficient in control microorganisms. The microbubbles treatment using water of 55 °C and pH =7-8 for 2 and 5 min reduced mesophilic aerobes on melon rind surface by 2 and 1.7 log₁₀cfu, respectively.

7. POSSIBLE APPLICATIONS AND SUGGESTIONS

7.1 Possible applications

On the ground of empirical findings in this work, some applications are drawn.

- This work provided basic information concerning different treatment temperatures and different treatment days after harvest of 1-MCP on four melon cultivars that could be useful in commercial practice.
- 1-MCP MBs proved to be an alternative technique in postharvest treatment for melon and other produces as well, particularly, when there is a lack of air tight storage room for conventional 1-MCP application.
- Microbubbles proved to be an alternative washing technique that could be applied in washing treatment.

7.2 Limitations and further researches

7.2.1 Limitations

Firstly, season is always in the short summer, therefore it was not easy to conduct sensory evaluation, and only self-sensory evaluation was carried out.

Secondly, so far there have not been so many publications about the storability of melon cultivars in Hungary. Hence, further researches in following years are highly recommended to make a discussion or for confirmation.

7.2.2 Further researches

Nevertheless, further researches about storability of melon in order to meet the market requirement are highly recommended. The topic surrounding postharvest management of melon is vast. The interesting topic nowadays is quality of melon comprising a set of standard about nutrition, safety and sensory characteristics of produce being suggested long ago as well (Ergun et al., 2005; Mayberry and Hartz, 1992; Nyarko et al., 2016; Ukuku, 2006). Therefore, sanitizing, treatment and proper handling should be together in order to solve postharvest problems of melon (Nyarko et al., 2016).

Many researches with various aspects would provide information about the response of melon to postharvest management. Moreover, further researches could have potential to surpass the following limitations of this work to gain more detail.

8. SUMMARY

Cantaloupe is a delicious fruit with its crispy, juicy texture, flavor and high nutritional value (Aguayo et al., 2007), particularly ‘Lillo’, ‘Centro’, ‘Celestial’ and ‘Donatello’ are the main melon cultivars in Hungary. However, after harvest the ripening process of melons are so quick that the softening of these fruit increases dramatically during several days of storage (Aharoni et al., 1993; Fallik et al., 2000). In addition, melon is a ground crop and thus microorganisms are available on the melon surface easily developing during transport and storage (Bastos et al., 2005). Therefore, maintaining the quality of melons meeting the market demand is the main target of postharvest management.

The aim of this thesis work was to prolong the storage life of melon. According to this, the experiments investigating the impact of 1-MCP treatment, storage condition and sanitizing methods on postharvest life of melon in two seasons from 2014 to 2015 were conducted.

Firstly, we evaluated the effect of gaseous 1-MCP at different treatment temperatures (5 °C, 10 °C and 20 °C), and different treatment days after harvest (1st, 3rd and 5th day) on 4 melon cultivars in Hungary (Lillo, Centro, Celestial and Donatello). The results indicated that there is no significant difference between 1-MCP treatment temperatures on melon during shelf-life. The earlier treatment is the better, however, 1-MCP application could delay till the 3rd day after harvest.

Secondly, 1-MCP microbubbles treatment was applied as an innovative technique for delaying the ripening of ‘Donatello’ melon, in comparison to conventional 1-MCP application in gaseous form. It is clear that 1-MCP MBs could overcome the limits of 1-MCP gaseous form. 1-MCP MBs application for 30 min has potential in delaying the ripening of melon.

Thirdly, we also investigated the effect of 1-MCP in combination with ozone or ethylene absorber on melon quality during 10 days storage at 5 °C plus 4 days of shelf-life at 20 °C. The results showed that ozone 0.1 ppm/h had effect on inhibiting microbial development during storage, but fungal growth resumed and much more serious, when fruits removed for further shelf-life. Ethylene absorber did not show any additional advantage throughout storage period. No significant difference was observed between 1-MCP alone or in combination with EA or ozone.

Finally, the efficacy of washing treatments: hot water, chlorine alone or in combination with microbubbles was investigated. Different treatments were used like hot water (55 °C, 2 and 5 min); chlorine (150 ppm, 2 and 5 min); ozone microbubbles (150 ppm, 2 and 5 min); hot water microbubbles (55 °C, 2 and 5 min); chlorine microbubbles (150 ppm, 2 and 5 min). The results indicated that ozone microbubbles for 5 min and hot water MBs treatment have potential in disinfection melon rind.

According to these findings, it is clear that 1-MCP treatment had strong efficacy in decreasing the ethylene production, respiration during storage of melon. In addition, 1-MCP application could slow the softening as well as the color change throughout postharvest life. However, the effectiveness of melon declined markedly with late treatment. 1-MCP MBs could serve as an alternative technique in postharvest treatment for melon, particularly, when lacking of air tight storage room for conventional 1-MCP application. Microbubbles offering a promising washing treatment could be applied in postharvest management. Besides, sanitizing should be applied together with proper handling in order to provide produce with good quality and microbial safety.

9. ACKNOWLEDGMENT

Foremost, I would like to sincerely and gratefully thank Dr. Hitka Géza and Dr. Zsom Tamás, my enthusiastic Supervisors, for their great supports, crucial advice and guidance during my PhD study period.

Besides, I would like to thank Stipendium Hungaricum program, Szent István University and my home University giving me an opportunity to broaden my knowledge and my mind.

I am thankful to the support provided by Agrofresh Polska Sp.z.o.o., The Fishmarket Halkereskedelmi Kft., and Capriovus Kft.

I also would like to thank Vivien Horváth providing melons for this PhD work.

More special thanks go to Department of Postharvest Science and Sensory Evaluation and the Department of Refrigeration and Livestock Products' Technology, especially professors, colleagues, classmates and staffs for their helps and encouragement.

10. REFERENCES

1. Abbott, J. A. (1999). Quality measurement of fruits and vegetables. *Postharvest Biology and Technology*, 15(3), 207-225.
2. Abe, K., & Watada, A. E. (1991). Ethylene absorbent to maintain quality of lightly processed fruits and vegetables. *Journal of Food Science*, 56(6), 1589-1592.
3. Agarwal, A., Ng, W. J., & Liu, Y. (2011). Principle and applications of microbubble and nanobubble technology for water treatment. *Chemosphere*, 84(9), 1175-1180.
4. Aguayo, E., Escalona, V. H., & Artés, F. (2006). Effect of cyclic exposure to ozone gas on physicochemical, sensorial and microbial quality of whole and sliced tomatoes. *Postharvest biology and technology*, 39(2), 169-177.
5. Aguayo, E., Escalona, V. H., & Artes, F. (2007). Quality of minimally processed *Cucumismelo* var. *saccharinus* as improved by controlled atmosphere. *European Journal of Horticultural Science*, 72(1), 39-45.
6. Aharoni, Y., Copel, A., & Fallik, E. (1993). Storing 'Galia' melons in a controlled atmosphere with ethylene absorbent. *HortScience*, 28(7), 725-726.
7. Al-Haq, M. I., Sugiyama, J., Tomizawa, A., & Sagara, Y. (2004). Non-destructive acoustic firmness tester detects the effect of manure on muskmelon texture. *HortScience*, 39(1), 142-145.
8. Ali, A., Ong, M. K., & Forney, C. F. (2014). Effect of ozone pre-conditioning on quality and antioxidant capacity of papaya fruit during ambient storage. *Food Chemistry*, 142, 19-26.
9. Alves, R. E., Filgueiras, H. A. C., Almeida, A. S., Machado, F. L. C., Bastos, M. S. R., Lima, M. A. C., & Miranda, M. R. A. (2005). Postharvest use of 1-MCP to extend storage life of melon in Brazil - Current research status. *Vol. 682. ActaHorticulturae* (pp. 2233-2238).
10. Argenta, L. C., Fan, X., & Mattheis, J. P. (2007). Responses of 'Golden Delicious' apples to 1-MCP applied in air or water. *HortScience*, 42(7), 1651-1655.
11. Baker, N. R., & Rosenqvist, E. (2004). Applications of chlorophyll fluorescence can improve crop production strategies: an examination of future possibilities. *Journal of Experimental Botany*, 55(403), 1607-1621.

12. Bai, J. H., Saftner, R., Watada, A., & Lee, Y. (2001). Modified atmosphere maintains quality of fresh-cut cantaloupe (*Cucumis melo* L.). *Journal of Food Science*, 66(8), 1207-1211.
13. Bai, X. H., Teng, L. H., Lu, D. Q., & Qi, H. H. (2014). Co-Treatment of EFF and 1-MCP for enhancing the shelf-life and aroma volatile compounds of oriental sweet melons (*Cucumis melo* var. *makuwa* Makino). *Journal of Integrative Agriculture*, 13(1), 217-227.
14. Bastos, M. d. S. R., de Fátima Ferreira Soares, N., José de Andrade, N., Cristina Arruda, A., & Elesbão Alves, R. (2005). The effect of the association of sanitizers and surfactant in the microbiota of the Cantaloupe (*Cucumis melo* L.) melon surface. *Food Control*, 16(4), 369-373.
15. Beaulieu, J. C., & Grimm, C. C. (2001). Identification of volatile compounds in cantaloupe at various developmental stages using solid phase microextraction. *Journal of Agricultural and Food Chemistry*, 49(3), 1345-1352.
16. Bett-Garber, K., Beaulieu, J., & Ingram, D. (2003). Effect of storage on sensory properties of fresh-cut cantaloupe varieties. *Journal of food quality*, 26(4), 323-335.
17. Blackbourn, H. D., Jeger, M. J., & John, P. (1990). Inhibition of degreening in the peel of bananas ripened at tropical temperatures. *Annals of Applied Biology*, 117(1), 175-186.
18. Blankenship, S. M., & Dole, J. M. (2003). 1-Methylcyclopropene: a review. *Postharvest Biology and Technology*, 28(1), 1-25.
19. Bonany, J., Buehler, A., Carbó, J., Codarin, S., Donati, F., Echeverria, G., & Schoorl, F. (2013). Consumer eating quality acceptance of new apple varieties in different European countries. *Food Quality and Preference*, 30(2), 250-259.
20. Bonany, J., Brugger, C., Buehler, A., Carbó, J., Codarin, S., Donati, F., & Schoorl, F. (2014). Preference mapping of apple varieties in Europe. *Food Quality and Preference*, 32, Part C, 317-329.
21. Botondi, R., Moscetti, R., & Massantini, R. (2016). A comparative study on the effectiveness of ozonated water and peracetic acid in the storability of packaged fresh-cut melon. *Journal of Food Science and Technology*, 53(5), 2352-2360.
22. Brecht, J., Chau, K., Fonseca, S., & Oliveira, F. (2001). CA transport of fresh produce in MAP: Designing systems for optimal atmosphere conditions throughout

- the postharvest handling chain. *Paper presented at the VIII International Controlled Atmosphere Research Conference.*
23. Bron, I. U., Ribeiro, R. V., Azzolini, M., Jacomino, A. P., & Machado, E. C. (2004). Chlorophyll fluorescence as a tool to evaluate the ripening of 'Golden' papaya fruit. *Postharvest Biology and Technology*, 33(2), 163-173.
 24. Byers, R. E., Carbaugh, D., & Combs, L. (2005). Ethylene inhibitors delay fruit drop, maturity, and increase fruit size of 'Arlet' apples. *HortScience*, 40(7), 2061-2065.
 25. Cagri, A., Ustunol, Z., & Ryser, E. T. (2004). Antimicrobial edible films and coatings. *Journal of Food Protection*, 67(4), 833-848.
 26. Callejón, R. M., Rodríguez-Naranjo, M. I., Ubeda, C., Hornedo-Ortega, R., Garcia-Parrilla, M. C., & Troncoso, A. M. (2015). Reported foodborne outbreaks due to fresh produce in the United States and European Union: trends and causes. *Foodborne pathogens and disease*, 12(1), 32-38.
 27. Ceponis, M.J., Cappellini, R.A., Lightner, G.W., (1986). Disorders in muskmelon shipments to the New York market, 1972-1984. *Plant Dis.* 70, 605-607.
 28. Choi, S. T., Tsouvaltzis, P., Lim, C. I., & Huber, D. J. (2008). Suppression of ripening and induction of a synchronous ripening in tomato and avocado fruits subjected to complete or partial exposure to aqueous solutions of 1-methylcyclopropene. *Postharvest Biology and Technology*, 48(2), 206-214.
 29. Cong, F., Zhang, Y., & Dong, W. (2007). Use of surface coatings with natamycin to improve the storability of Hami melon at ambient temperature. *Postharvest Biology and Technology*, 46(1), 71-75.
 30. Conte, J., El Blidi, A., Rigal, L., & Torres, L. (1992). Ethylene removal in fruit storage rooms: A catalytic oxidation reactor at low temperature. *Journal of Food Engineering*, 15(4), 313-329.
 31. Dauny, P. T., & Joyce, D. C. (2002). 1-MCP improves storability of 'Queen Cox' and 'Bramley' apple fruit. *HortScience*, 37(7), 1082-1085.
 32. De Ketelaere, B., Howarth, M. S., Crezee, L., Lammertyn, J., Viaene, K., Bulens, I., & De Baerdemaeker, J. (2006). Postharvest firmness changes as measured by acoustic and low-mass impact devices: a comparison of techniques. *Postharvest biology and technology*, 41(3), 275-284.

33. DeEll, J. R., Murr, D. P., Porteous, M. D., & Vasantha Rupasinghe, H. P. (2002). Influence of temperature and duration of 1-methylcyclopropene (1-MCP) treatment on apple quality. *Postharvest Biology and Technology*, 24(3), 349-353.
34. Dong, L., Lurie, S., & Zhou, H. W. (2002). Effect of 1-methylcyclopropene on ripening of 'Canino' apricots and 'Royal Zee' plums. *Postharvest Biology and Technology*, 24(2), 135-145.
35. Du Chatenet, C., Latché, A., Olmos, E., Ranty, B., Charpentreau, M., Ranjeva, R., Graziana, A. (2000). Spatial-resolved analysis of histological and biochemical alterations induced by water-soaking in melon fruit. *Physiologia Plantarum*, 110(2), 248-255.
36. Elfving, D. C., Drake, S. R., Reed, A. N., & Visser, D. B. (2007). Preharvest applications of sprayable 1-methylcyclopropene in the orchard for management of apple harvest and postharvest condition. *HortScience*, 42(5), 1192-1199.
37. Ergun, M., Jeong, J., Huber, D. J., & Cantliffe, D. J. (2005). Suppression of ripening and softening of 'Galia' melons by 1-methylcyclopropene applied at preripe or ripe stages of development. *HortScience*, 40(1), 170-175.
38. Ergun, M., Jeong, J., Huber, D. J., & Cantliffe, D. J. (2007). Physiology of fresh-cut 'Galia' (*Cucumis melo* var. *reticulatus*) from ripe fruit treated with 1-methylcyclopropene. *Postharvest Biology and Technology*, 44(3), 286-292.
39. Fallik, E., Aharoni, Y., Copel, A., Rodov, V., Tuvia-Alkalai, S., Horev, B., Regev, R. (2000). Reduction of postharvest losses of Galia melon by a short hot-water rinse. *Plant pathology*, 49(3), 333-338.
40. Fallik, E. (2004). Prestorage hot water treatments (immersion, rinsing and brushing). *Postharvest Biology and Technology*, 32(2), 125-134.
41. Fan, S., Guo, Z., Zhang, B., Huang, W., & Zhao, C. (2015). Using Vis/NIR Diffuse Transmittance Spectroscopy and Multivariate Analysis to Predicate Soluble Solids Content of Apple. *Food Analytical Methods*.
42. Fan, X., Annous, B. A., Sokorai, K. J., Burke, A., & Mattheis, J. P. (2006). Combination of hot-water surface pasteurization of whole fruit and low-dose gamma irradiation of fresh-cut cantaloupe. *Journal of Food Protection*, 69(4), 912-919.
43. FAO 2013. Food and Agricultural commodities production. In: <http://faostat.fao.org> (accessed July 2015).

44. FAO (2014) Food and Agricultural Organization of the United Nations: FAOSTAT <http://faostat3.fao.org/faostat-gateway/go/to/download/Q/QC/E>
45. Fogelman, E., Kaplan, A., Tanami, Z., & Ginzberg, I. (2011). Antioxidative activity associated with chilling injury tolerance of muskmelon (*Cucumis melo* L.) rind. *Scientia Horticulturae*, 128(3), 267-273.
46. FruitVeB Hungarian Interprofessional Organisation for Fruit and Vegetables, 2014.
47. Gagliardi, J., Millner, P., Lester, G., & Ingram, D. (2003). On-farm and postharvest processing sources of bacterial contamination to melon rinds. *Journal of Food Protection*, 66(1), 82-87.
48. Gal, S., Alkalai-Tuvia, S., Elkind, Y., & Fallik, E. (2006). Influence of different concentrations of 1-methylcyclopropene and times of exposure on the quality of 'Galia'-type melon harvested at different stages of maturity. *Journal of Horticultural Science and Biotechnology*, 81(6), 975-982.
49. Gil, M. I., Selma, M. V., López-Gálvez, F., & Allende, A. (2009). Fresh-cut product sanitation and wash water disinfection: problems and solutions. *International Journal of Food Microbiology*, 134(1), 37-45.
50. Golden, D. A., Rhodehamel, E. J., & Kautter, D. A. (1993). Growth of *Salmonella* spp. in cantaloupe, watermelon, and honeydew melons. *Journal of Food Protection*, 56(3), 194-196.
51. Golding, J. B., Shearer, D., Wyllie, S. G., & McGlasson, W. B. (1998). Application of 1-MCP and propylene to identify ethylene-dependent ripening processes in mature banana fruit. *Postharvest Biology and Technology*, 14(1), 87-98.
52. Gorbe, E., & Calatayud, A. (2012). Applications of chlorophyll fluorescence imaging technique in horticultural research: A review. *Scientia Horticulturae*, 138, 24-35
53. Guzel-Seydim, Z. B., Greene, A. K., & Seydim, A. C. (2004). Use of ozone in the food industry. *LWT - Food Science and Technology*, 37(4), 453-460.
54. Habibi Najafi, M. B., & Haddad Khodaparast, M. H. (2009). Efficacy of ozone to reduce microbial populations in date fruits. *Food Control*, 20(1), 27-30.
55. Hall, J. N., Moore, S., Harper, S. B., & Lynch, J. W. (2009). Global Variability in Fruit and Vegetable Consumption. *American Journal of Preventive Medicine*, 36(5), 402-409.

56. Harris, D. R., Seberry, J. A., Wills, R. B. H., & Spohr, L. J. (2000). Effect of fruit maturity on efficiency of 1-methylcyclopropene to delay the ripening of bananas. *Postharvest Biology and Technology*, 20(3), 303-308.
57. Hernández-Sánchez, N., Hills, B. P., Barreiro, P., & Marigheto, N. (2007). An NMR study on internal browning in pears. *Postharvest biology and technology*, 44(3), 260-270.
58. Hitka, G., Zsom, T., Nguyen, L., & Balla, C. (2014). Effect of 1-methylcyclopropene on 'Bosc Kobak' pears. *Acta Alimentaria*, 43 (1), 73-77.
59. Jeong, J., Brecht, J. K., Huber, D. J., & Sargent, S. A. (2008). Storage life and deterioration of intact cantaloupe (*Cucumis melo* L. var. *reticulatus*) fruit treated with 1-methylcyclopropene and fresh-cut cantaloupe prepared from fruit treated with 1-methylcyclopropene before processing. *HortScience*, 43(2), 435-438.
60. Jia, X., Xia, Y., Wang, W., Tong, W., Jiang, Y., & Wang, Z. (2014). Effects of harvest maturity combined with 1-MCP on storage quality and its physiological property of apple. *Journal of Chinese Institute of Food Science and Technology*, 14(8), 197-203.
61. Jyoti, K., & Pandit, A. (2004). Ozone and cavitation for water disinfection. *Biochemical Engineering Journal*, 18(1), 9-19.
62. Kader, A. A., Zagory, D., Kerbel, E. L., & Wang, C. Y. (1989). Modified atmosphere packaging of fruits and vegetables. *Critical Reviews in Food Science & Nutrition*, 28(1), 1-30.
63. Kato, K. (1997). Electrical density sorting and estimation of soluble solids content of watermelon. *Journal of Agricultural Engineering Research*, 67(2), 161-170.
64. Kim, J. G., Yousef, A. E., & Dave, S. (1999). Application of ozone for enhancing the microbiological safety and quality of foods: a review. *Journal of Food Protection*, 62(9), 1071-1087.
65. Kirkbride, J. H., 1993. Biosystematic monograph of the Genus *Cucumis* (Cucurbitaceae). Parkway, North Carolina, p. 159.
66. Kubo, Y., Hiwasa, K., Owino, W. O., Nakano, R., & Inaba, A. (2003). Influence of time and concentration of 1-MCP application on the shelf life of pear 'La France' Fruit. *HortScience*, 38(7), 1414-1416.
67. Liew, C. L., & Prange, R. K. (1994). Effect of ozone and storage temperature on postharvest diseases and physiology of carrots (*Daucus carota* L.). *Journal of the American Society for Horticultural Science*, 119(3), 563-567.

68. Lima, M. A. C. d., Alves, R. E., Biscegli, C. I., Filgueiras, H. A. C., & Coccoza, F. d. M. (2004). Conservaçãopós-colheita de melõesGalia 'Solar King' tratados com 1-metilciclopropreno. (Postharvest storage of Galia 'Solar King' muskmelon treated with 1-methylcyclopropene). *Horticultura Brasileira*, 22(1), 121-126.
69. Liu, Y., & Ying, Y. (2005). Use of FT-NIR spectrometry in non-invasive measurements of internal quality of 'Fuji' apples. *Postharvest Biology and Technology*, 37(1), 65-71.
70. Marui, T. (2010). *An introduction to micro/nano-bubbles and their applications*. Paper presented at The 14th World Multi-Conference on Systemics, Cybernetics and Informatics, International Social Science Council, Orlando.
71. Mayberry, K., & Hartz, T. (1992). Extension of muskmelon storage through the use of hot water life treatment and polyethylene wraps. *HortScience*, 27(4), 324-326.
72. McSpadden, K. E., Patrick, H., Oh, A. Y., Yaroch, A. L., Dwyer, L. A., & Nebeling, L. C. (2016). The association between motivation and fruit and vegetable intake: The moderating role of social support. *Appetite*, 96, 87-94.
73. Meyer, M. D., & Terry, L. A. (2010). Fatty acid and sugar composition of avocado, cv. Hass, in response to treatment with an ethylene scavenger or 1-methylcyclopropene to extend storage life. *Food Chemistry*, 121(4), 1203-1210.
74. Miccolis, V., & Saltveit, M. E. (1995). Influence of storage period and temperature on the postharvest characteristics of six melon (*Cucumis melo* L., Inodorus Group) cultivars. *Postharvest biology and technology*, 5(3), 211-219.
75. Milczarek, R. R., Saltveit, M. E., Garvey, T. C., & McCarthy, M. J. (2009). Assessment of tomato pericarp mechanical damage using multivariate analysis of magnetic resonance images. *Postharvest biology and technology*, 52(2), 189-195.
76. Mir, N. A., Curell, E., Khan, N., Whitaker, M., & Beaudry, R. M. (2001). Harvest maturity, storage temperature, and 1-MCP application frequency alter firmness retention and chlorophyll fluorescence of 'Red chief Delicious' apples. *Journal of the American Society for Horticultural Science*, 126(5), 618-624.
77. Mizrach, A., Galili, N., Teitel, D., & Rosenhouse, G. (1994). Ultrasonic evaluation of some ripening parameters of autumn and winter-grown 'Galia' melons. *Scientia Horticulturae*, 56(4), 291-297.
78. Mizrach, A., Galili, N., Gan-Mor, S., Flitsanov, U., & Prigozin, I. (1996). Models of ultrasonic parameters to assess avocado properties and shelf life. *Journal of Agricultural Engineering Research*, 65(4), 261-267.

79. Mujcic, R., & Oswald, A. J. (2016). Evolution of well-being and happiness after increases in consumption of fruit and vegetables. *American Journal of Public Health, 106*(8), 1504-1510.
80. Nedbal, L., Soukupová, J., Whitmarsh, J., & Trtílek, M. (2000). Postharvest imaging of chlorophyll fluorescence from lemons can be used to predict fruit quality. *Photosynthetica, 38*(4), 571-579.
81. Nelson, S., Trabelsi, S., & Kays, S. (2006). Dielectric spectroscopy of honeydew melons from 10 MHz to 1.8 GHz for quality sensing. *Transactions of the ASABE, 49*(6), 1977-1981.
82. Nelson, S. O., Guo, W. C., Trabelsi, S., & Kays, S. J. (2007). Dielectric spectroscopy of watermelons for quality sensing. *Measurement Science and Technology, 18*(7), 1887.
83. Nguyen, L., Hitka, G., Zsom, T., & Kókai, Z. (2016). Application of 1-MCP on apricots at different temperatures and days after harvest. *Acta Alimentaria, 45*(4), 542-550.
84. Noh, S. H., & Choi, K. H. (2006). *Non-destructive quality evaluation technology for fruits and vegetables*. Paper presented at the International seminar on enhancing export competitiveness of Asian fruits, Bangkok, Thailand.
85. Nyarko, E., Kniel, K. E., Millner, P. D., Luo, Y., Handy, E. T., Reynnells, R., & Sharma, M. (2016). Survival and growth of *Listeria monocytogenes* on whole cantaloupes is dependent on site of contamination and storage temperature. *International Journal of Food Microbiology, 234*, 65-70.
86. O'Connor-Shaw, R., Roberts, R., Ford, A., & Nottingham, S. (1996). Changes in sensory quality of sterile cantaloupe dice stored in controlled atmospheres. *Journal of Food Science, 61*(4), 847-851.
87. Oms-Oliu, G., Soliva-Fortuny, R., & Martín-Belloso, O. (2008). Modeling changes of headspace gas concentrations to describe the respiration of fresh-cut melon under low or superatmospheric oxygen atmospheres. *Journal of Food Engineering, 85*(3), 401-409.
88. Paliyath, G., Murr, D. P., Handa, A. K., & Lurie, S. (2009). *Postharvest biology and technology of fruits, vegetables, and flowers*: John Wiley & Sons, p. 308-310.
89. Palou, L. s., Crisosto, C. H., Smilanick, J. L., Adaskaveg, J. E., & Zoffoli, J. P. (2002). Effects of continuous 0.3 ppm ozone exposure on decay development and

- physiological responses of peaches and table grapes in cold storage. *Postharvest Biology and Technology*, 24(1), 39-48.
90. Park, J. S., & Kurata, K. (2009). Application of microbubbles to hydroponics solution promotes lettuce growth. *HortTechnology*, 19(1), 212-215.
 91. Paull, R. E., & Chen, N. J. (2000). Heat treatment and fruit ripening. *Postharvest Biology and Technology*, 21(1), 21-37.
 92. Perzelan, Y., Alkalai-Tuvia, S., Weinberg, T., & Fallik, E. (2014). 1-MCP and melon after harvest: optimal application and the influence on different cultivars. *Agriculture & Forestry*, 60(1), 5-14.
 93. Pérez-Jiménez, J., & Saura-Calixto, F. (2015). Macromolecular antioxidants or non-extractable polyphenols in fruit and vegetables: Intake in four European countries. *Food Research International*, 74, 315-323.
 94. Ponce, P., Carbonari, G. L., & Lugão, A. B. (2002). Active packaging using ethylene absorber to extend shelf-life. *Food Additives and Contaminants*, 19, 144-162.
 95. Pongprasert, N., & Srilaong, V. (2014). A novel technique using 1-MCP microbubbles for delaying postharvest ripening of banana fruit. *Postharvest Biology and Technology*, 95, 42-45.
 96. Qi, L., Wu, T., & Watada, A. E. (1999). Quality changes of fresh-cut honeydew melons during controlled atmosphere storage. *Journal of food quality*, 22(5), 513-521.
 97. Raybaudi-Massilia, R. M., Mosqueda-Melgar, J., & Martín-Belloso, O. (2008). Edible alginate-based coating as carrier of antimicrobials to improve shelf-life and safety of fresh-cut melon. *International Journal of Food Microbiology*, 121(3), 313-327.
 98. Saltveit, M. E. (2003). Is it possible to find an optimal controlled atmosphere ? *Postharvest biology and technology*, 27(1), 3-13.
 99. Salvador, A., Abad, I., Arnal, L., & Martínez-Jávega, J. M. (2006). Effect of Ozone on Postharvest Quality of Persimmon. *Journal of Food Science*, 71(6), S443-S446.
 100. Sammi, S., & Masud, T. (2007). Effect of different packaging systems on storage life and quality of tomato (*Lycopersicon esculentum* var. Rio Grande) during different ripening stages. *Internet Journal of food safety*, 9, 37-44.

101. Sapers, G., Miller, R., Pilizota, V., & Mattrazzo, A. (2001). Antimicrobial treatments for minimally processed cantaloupe melon. *Journal of Food Science*, 66(2), 345-349.
102. Sarig, P., Zahavi, T., Zutkhi, Y., Yannai, S., Lisker, N., & Ben-Arie, R. (1996). Ozone for control of post-harvest decay of table grapes caused by *Rhizopusstolonifer*. *Physiological and Molecular Plant Pathology*, 48(6), 403-415.
103. Schotte, S., De Belie, N., & De Baerdemaeker, J. (1999). Acoustic impulse-response technique for evaluation and modelling of firmness of tomato fruit. *Postharvest biology and technology*, 17(2), 105-115.
104. Selma, M. V., Ibáñez, A. M., Cantwell, M., & Suslow, T. (2008). Reduction by gaseous ozone of Salmonella and microbial flora associated with fresh-cut cantaloupe. *Food Microbiology*, 25(4), 558-565.
105. Seymour, G., & McGlasson, W. (1993). Melons. *Biochemistry of fruit ripening* (pp. 273-290): Springer.
106. Shi, Y., Wang, B., Shui, D., Cao, L., Wang, C., Yang, T., Ye, H. (2014). Effect of 1-methylcyclopropene on shelf life, visual quality and nutritional quality of netted melon. *Food SciTechnol Int*.
107. Silva, D. F. P., Salomão, L. C. C., Siqueira, D. L. d., Cecon, P. R., & Rocha, A. (2009). Potassium permanganate effects in postharvest conservation of the papaya cultivar Sunrise Golden. *Pesquisa Agropecuaria Brasileira*, 44(7), 669-675.
108. Silveira, A. C., Conesa, A., Aguayo, E., & Artes, F. (2008). Alternative sanitizers to chlorine for use on fresh-cut 'Galia' (*Cucumis melo* var. *catalupensis*) melon. *Journal of Food Science*, 73(9), 405-411.
109. Silveira, A., Aguayo, E., & Artés, F. (2010). Emerging sanitizers and Clean Room packaging for improving the microbial quality of fresh-cut 'Galia' melon. *Food Control*, 21(6), 863-871.
110. Simmons, G. F., Rij, R., Smilanick, J. L., & John, S. (1996). Microbial population reduction on cantaloupe destined for the minimally processed market using vapor hydrogen peroxide or SO. *HortScience*, 31(4), 600-600.
111. Sisler, E. C. (2006). The discovery and development of compounds counteracting ethylene at the receptor level. *Biotechnology Advances*, 24(4), 357-367.
112. Skog, & CL Chu, L. (2001). Effect of ozone on qualities of fruits and vegetables in cold storage. *Canadian Journal of Plant Science*, 81(4), 773-778.

113. Song, J., Deng, W., Beaudry, R. M., & Armstrong, P. R. (1997). Changes in chlorophyll fluorescence of apple fruit during maturation, ripening, and senescence. *HortScience*, 32(5), 891-896.
114. Sozzi, G. O., & Beaudry, R. M. (2007). Current perspectives on the use of 1-methylcyclopropene in tree fruit crops: An international survey. *Stewart Postharvest Review*, 3(2).
115. Sugiyama, J., Otobe, K., Hayashi, S., & Usui, S. (1994). Firmness measurement of muskmelons by acoustic impulse transmission. *Transactions of the ASAE*, 37(4), 1235-1241.
116. Sugiyama, J., Katsurai, T., Hong, J., Koyama, H., & Mikuriya, K. (1998). Melon ripeness monitoring by a portable firmness tester. *Transactions of the ASAE*, 41(1), 121.
117. Sumikura, M., Hidaka, M., Murakami, H., Nobutomo, Y., & Murakami, T. (2007). Ozone micro-bubble disinfection method for waste water reuse system. *Water Science and Technology*, 56(5), 53-61.
118. Sun, T., Huang, K., Xu, H., & Ying, Y. (2010). Research advances in nondestructive determination of internal quality in watermelon/melon: A review. *Journal of Food Engineering*, 100(4), 569-577.
119. Takahashi, M., Chiba, K., & Li, P. (2007). Free-radical generation from collapsing microbubbles in the absence of a dynamic stimulus. *The Journal of Physical Chemistry B*, 111(6), 1343-1347.
120. Terry, L. A., Ilkenhans, T., Poulston, S., Rowsell, L., & Smith, A. W. (2007). Development of new palladium-promoted ethylene scavenger. *Postharvest Biology and Technology*, 45(2), 214-220.
121. Ukuku, D. O. (2006). Effect of sanitizing treatments on removal of bacteria from cantaloupe surface, and re-contamination with Salmonella. *Food Microbiology*, 23(3), 289-293.
122. USDA. Code of Federal Regulations, Title 9, Part 381.66—poultry products; temperatures and chilling and freezing procedures. (1997). Office of the Federal Register National Archives and Records Administration, Washington, DC.
123. USDA. 2006 (accessed August 2016)
124. USDA. 2013. Vegetables 2012 summary. U.S. Dept. Agr., Washington, DC.
125. U.S. Food and Drug Administration, January 1, 2008 (accessed November 2015)

126. Vallejo, F., & Beaudry, R. (2006). Depletion of 1-MCP by 'non-target' materials from fruit storage facilities. *Postharvest biology and technology*, 40(2), 177-182.
127. Vermeiren, L., Devlieghere, F., van Beest, M., de Kruijf, N., & Debevere, J. (1999). Developments in the active packaging of foods. *Trends in Food Science & Technology*, 10(3), 77-86.
128. Victorin, K. (1992). Review of the genotoxicity of ozone. *Mutation Research/Reviews in Genetic Toxicology*, 277(3), 221-238.
129. Watkins, C. B., & Nock, J. F. (2005). Effects of delays between harvest and 1-methylcyclopropene treatment, and temperature during treatment, on ripening of air-stored and controlled- atmosphere-stored apples. *HortScience*, 40(7), 2096-2101.
130. Watkins, C. B. (2006). The use of 1-methylcyclopropene (1-MCP) on fruits and vegetables. *Biotechnology Advances*, 24(4), 389-409.
131. Watkins, C. B. (2008). Overview of 1-methylcyclopropene trials and uses for edible horticultural crops. *HortScience*, 43(1), 86-94.
132. WHO (2003). Diet, nutrition and the prevention of chronic diseases. Report of a Joint WHO/FAO Expert Consultation. Geneva: WHO Technical Report Series 916.
133. Wills, R. B. H., & Ku, V. V. V. (2002). Use of 1-MCP to extend the time to ripen of green tomatoes and postharvest life of ripe tomatoes. *Postharvest Biology and Technology*, 26(1), 85-90.
134. Yang, B., Shiping, T., Hongxia, L., Jie, Z., Jiankang, C., Yongcai, L., & Weiyi, Z. (2003). Effect of temperature on chilling injury, decay and quality of Hami melon during storage. *Postharvest Biology and Technology*, 29(2), 229-232.
135. Yuan, R., & Carbaugh, D. H. (2007). Effects of NAA, AVG, and 1-MCP on ethylene biosynthesis, preharvest fruit drop, fruit maturity, and quality of 'Golden Supreme' and 'Golden Delicious' apples. *HortScience*, 42(1), 101-105.
136. Zagory, D. (1995). Ethylene-removing packaging *Active food packaging* (pp. 38-54)
137. Zhang, L., Lu, Z., Yu, Z., & Gao, X. (2005). Preservation of fresh-cut celery by treatment of ozonated water. *Food Control*, 16(3), 279-283.
138. Zhang, Z., Huber, D. J., Hurr, B. M., & Rao, J. (2009). Delay of tomato fruit ripening in response to 1-methylcyclopropene is influenced by internal ethylene levels. *Postharvest Biology and Technology*, 54(1), 1-8.
139. Zhang, Z., Huber, D. J., & Rao, J. (2011). Ripening delay of mid-climacteric avocado fruit in response to elevated doses of 1-methylcyclopropene and hypoxia-

- mediated reduction in internal ethylene concentration. *Postharvest Biology and Technology*, 60(2), 83-91.
140. Zimmerman, W. B., Tesař, V., & Bandulasena, H. C. H. (2011). Towards energy efficient nanobubble generation with fluidic oscillation. *Current Opinion in Colloid & Interface Science*, 16(4), 350-356.
141. Zsom-Muha, V., & Felföldi, J. (2007). Vibration behavior of long shape vegetables. *Progress in Agricultural Engineering Sciences*, 3(1), 21-46.

Web references

1. Bioconservacion(<http://www.bioconservacion.com/en/products/ethyl-stopper-sachets>)accessed 2016/08/15
2. Clause vegetable seed (<http://www.mezogazdasagibolt.hu/termek/CL0070/lillo-f-1500-szem-s-rgadinnye-vet-mag>) accessed 2016/08/15
3. Neo. Tec XJ 100 (<http://neotecir.com/en/xj-100.php>) accessed 2016/08/15
4. Nunhemsvegetable seed (<http://www.mezogazdasagibolt.hu/termek/NUN88017/celestial-f-1-500-szem-s-rgadinnye-vet-mag>)accessed 2016/08/15
5. Postharvest Technology Center, UC Davis, USA (http://postharvest.ucdavis.edu/Commodity_Resources/Fact_Sheets/Datastores/Fruit_English/?uid=14&ds=798) accessed 2016/08/15
6. Sárgadinnyeárlista(<http://www.szatmarivetomag.hu/index.php/sargadinnye>) accessed 2016/08/15

11. APPENDIX

Appendix 1 - Pictures

1. Application of 1-MCP at different temperatures

1.1 Centro

1.1.1 Outside and inside after shelf-life

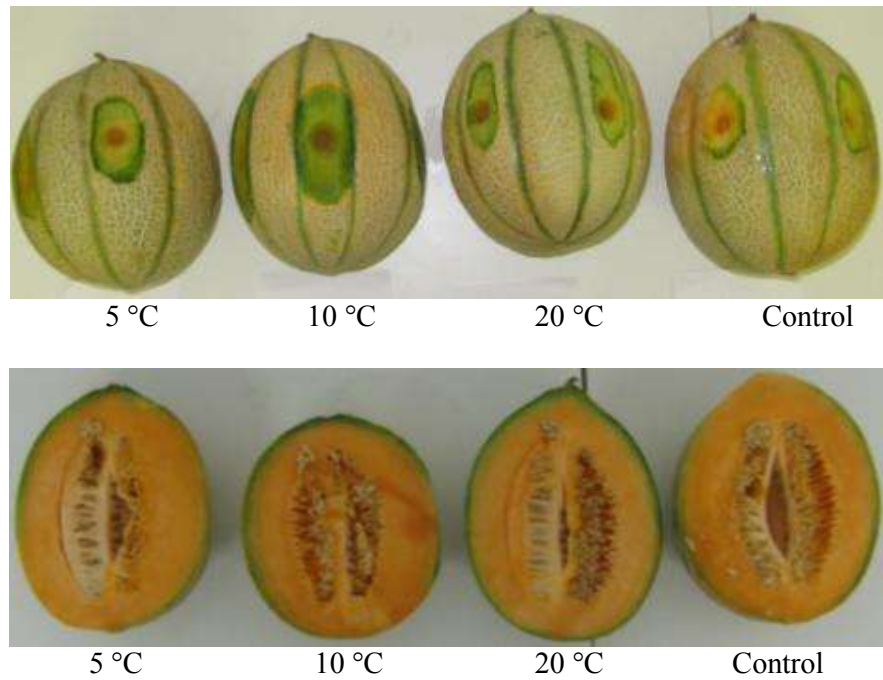

Figure 1. Outside and inside of melon at different treatment temperature after shelf-life

1.1.2 Decays



Figure 2. Rot at stem end



Figure 3. Microorganisms on melon surface

1.2 Lillo, Celestial, and Donatello

Lillo, Celestial, and Donatello had the similar results to Centro.

2. Application of 1-MCP at different days after harvest

2.1 Donatello



Figure 4. Initial time



5th day 3rd day 1st day Control

Figure 5. Melon at different treatment days after shelf-life

3. Comparison of conventional 1-MCP and 1-MCP microbubbles (1-MCP MBs)



Control 1-MCP 1-MCP MBs: 45 min 30 min 15 min

Figure 6. Melon treated with conventional 1-MCP and 1-MCP MBs after shelf-life

4. Application of conventional 1-MCP, ethylene absorber and ozone

4.1 Chilling injury



Figure 7. Chilling injury



Ozone 1-MCP + ozone Control

Figure 8. Decay after 10 days of storage at 5 °C and 4 days of shelf-life

4.2 Inside



Control Ethylene absorber (EA) Ozone













1-MCP 1-MCP + EA 1-MCP + O₃

Figure 9. Melon at different treatments after shelf-life

5. Washing treatment

Table 1. Melon after washing and shelf-life

Treatment	After washing	4 days of shelf-life
Tap water		
Hot water (2 min)		
Hot water (5 min)		
Hot water MB (2 min)		
Hot water MB (5 min)		

Chlorine (2 min)		
Chlorine (5 min)		
Chlorine MB (2 min)		
Chlorine MB (5 min)		
Ozone MB (2 min)		
Ozone MB (5 min)		

Appendix 2 – Statistical results

1. Experiment 1.1: Application of 1-MCP at different treatment temperatures

1.1 Centro

1.1.1 Ethylene production

Tests of Between-Subjects Effects

Dependent Variable: Ethylene

Source	Type III Sum of Squares	df	Mean Square	F	Sig.
Corrected Model	16389.170 ^a	47	348.706	216.321	.000
Intercept	124741.940	1	124741.940	77384.000	.000
Treatment	1960.607	3	653.536	405.423	.000
Time	12347.856	2	6173.928	3830.013	.000
Cultivar	695.836	3	231.945	143.888	.000
Treatment * Time	983.124	6	163.854	101.647	.000
Treatment * Cultivar	43.755	9	4.862	3.016	.003
Time * Cultivar	308.235	6	51.372	31.869	.000
Treatment * Time *	49.757	18	2.764	1.715	.050
Cultivar					
Error	154.751	96	1.612		
Total	141285.861	144			
Corrected Total	16543.921	143			

a. R Squared = .991 (Adjusted R Squared = .986)

Ethylene

Tukey HSD^{a,b}

Treatment	N	Subset	
		1	2
20 degree C	36	27.0026	
10 degree C	36	27.1609	
5 degree C	36	27.7613	
Control	36		35.8046
Sig.		.061	1.000

Means for groups in homogeneous subsets are displayed.

Based on observed means.

The error term is Mean Square (Error) = 1.612.

a. Uses Harmonic Mean Sample Size = 36.000.

b. Alpha = .05.

EthyleneTukey HSD^{a,b}

Time	N	Subset		
		1	2	3
9th day	48	19.9775		
6th day	48		26.3127	
day 0	48			42.0069
Sig.		1.000	1.000	1.000

Means for groups in homogeneous subsets are displayed.

Based on observed means.

The error term is Mean Square (Error) = 1.612.

a. Uses Harmonic Mean Sample Size = 48.000.

b. Alpha = .05.

EthyleneTukey HSD^{a,b}

Cultivar	N	Subset			
		1	2	3	4
Lillo	36	26.7766			
Donatello	36		28.0023		
Centro	36			30.5046	
Celestial	36				32.4458
Sig.		1.000	1.000	1.000	1.000

Means for groups in homogeneous subsets are displayed.

Based on observed means.

The error term is Mean Square (Error) = 1.612.

a. Uses Harmonic Mean Sample Size = 36.000.

b. Alpha = .05.

1.1.2 CO₂ production

Tests of Between-Subjects Effects

Dependent Variable: CO₂

Source	Type III Sum of Squares	df	Mean Square	F	Sig.
Corrected Model	2677.445 ^a	47	56.967	45.462	.000
Intercept	74289.472	1	74289.472	59286.488	.000
Treatment	342.198	3	114.066	91.030	.000
Time	2006.129	2	1003.065	800.493	.000
Cultivar	75.628	3	25.209	20.118	.000
Treatment * Time	175.375	6	29.229	23.326	.000
Treatment * Cultivar	19.434	9	2.159	1.723	.094
Time * Cultivar	38.190	6	6.365	5.080	.000
Treatment * Time *	20.490	18	1.138	.908	.570
Cultivar					
Error	120.294	96	1.253		
Total	77087.211	144			
Corrected Total	2797.739	143			

a. R Squared = .957 (Adjusted R Squared = .936)

CO₂

Tukey HSD^{a,b}

Treatment	N	Subset	
		1	2
5 degree C	36	21.4601	
20 degree C	36	21.9753	
10 degree C	36	22.0649	
Control	36		25.3534
Sig.		.107	1.000

Means for groups in homogeneous subsets are displayed.

Based on observed means.

The error term is Mean Square (Error) = 1.253.

a. Uses Harmonic Mean Sample Size = 36.000.

CO₂

Time	N	Subset		
		1	2	3
9th day	48	18.7636		
6th day	48		21.6557	
day 0	48			27.7209
Sig.		1.000	1.000	1.000

Means for groups in homogeneous subsets are displayed.

Based on observed means.

The error term is Mean Square (Error) = 1.253.

a. Uses Harmonic Mean Sample Size = 48.000.

b. Alpha = .05.

CO₂

Tukey HSD^{a,b}

Cultivar	N	Subset	
		1	2
Lillo	36	21.4746	
Celestial	36		22.9725
Donatello	36		23.1059
Centro	36		23.3007
Sig.		1.000	.601

Means for groups in homogeneous subsets are displayed.

Based on observed means.

The error term is Mean Square (Error) = 1.253.

a. Uses Harmonic Mean Sample Size = 36.000.

b. Alpha = .05.

1.1.3 Acoustic firmness

Tests of Between-Subjects Effects

Dependent Variable: Acoustic firmness

Source	Type III Sum of Squares	df	Mean Square	F	Sig.
Corrected Model	74218.282 ^a	11	6747.117	705.632	.000
Intercept	527431.894	1	527431.894	55160.259	.000
Treatment	5154.039	3	1718.013	179.674	.000
Time	65908.489	2	32954.244	3446.444	.000
Treatment *Time	3155.754	6	525.959	55.006	.000
Error	1606.384	168	9.562		
Total	603256.560	180			
Corrected Total	75824.666	179			

a. R Squared = .979 (Adjusted R Squared = .977)

Acoustic firmness

Tukey HSD^{a,b}

Treatment	N	Subset	
		1	2
Control	45	44.9044	
20 degree C	45		56.7756
5 degree C	45		56.8111
10 degree C	45		58.0333
Sig.		1.000	.220

Means for groups in homogeneous subsets are displayed.

Based on observed means.

The error term is Mean Square (Error) = 9.562.

a. Uses Harmonic Mean Sample Size = 45.000.

b. Alpha = .05.

1.1.4 Hue angle value

Tests of Between-Subjects Effects

Dependent Variable: Hue angle value

Source	Type III Sum of Squares	df	Mean Square	F	Sig.
Corrected Model	9005.992 ^a	11	818.727	84.902	.000
Intercept	1298236.586	1	1298236.586	134627.739	.000
Treatment	1065.283	3	355.094	36.823	.000
Time	7537.201	2	3768.601	390.806	.000
Treatment *Time	403.507	6	67.251	6.974	.000
Error	1620.051	168	9.643		
Total	1308862.628	180			
Corrected Total	10626.042	179			

a. R Squared = .848 (Adjusted R Squared = .838)

Hue

Tukey HSD^{a,b}

Time	N	Subset		
		1	2	3
9th day	60	78.0375		
6th day	60		83.1528	
day 0	60			93.5877
Sig.		1.000	1.000	1.000

Means for groups in homogeneous subsets are displayed.

Based on observed means.

The error term is Mean Square (Error) = 9.643.

a. Uses Harmonic Mean Sample Size = 60.000.

b. Alpha = .05.

1.1.5 Chlorophyll fluorescence parameter

1.1.5.1 F_m

Tests of Between-Subjects Effects

Dependent Variable: F_m

Source	Type III Sum of Squares	df	Mean Square	F	Sig.
Corrected Model	4342334.036 ^a	11	394757.640	2139.608	.000
Intercept	44213140.119	1	44213140.119	239637.621	.000
Treatment	421014.561	3	140338.187	760.641	.000
Time	3708515.673	2	1854257.836	10050.178	.000
Treatment*Time	212803.802	6	35467.300	192.235	.000
Error	30995.999	168	184.500		
Total	48586470.155	180			
Corrected Total	4373330.035	179			

a. R Squared = .993 (Adjusted R Squared = .992)

F_m

Tukey HSD^{a,b}

Treatment	N	Subset	
		1	2
Control	45	411.9700	
20 degree C	45		521.1484
10 degree C	45		521.4742
5 degree C	45		527.8444
Sig.		1.000	.094

Means for groups in homogeneous subsets are displayed.

Based on observed means.

The error term is Mean Square(Error) = 184.500.

a. Uses Harmonic Mean Sample Size = 45.000.

b. Alpha = .05.

F_m

Tukey HSD^{a,b}

Time	N	Subset		
		1	2	3
9th day	60	346.0722		
6th day	60		451.4943	
day 0	60			689.2613
Sig.		1.000	1.000	1.000

Means for groups in homogeneous subsets are displayed.

Based on observed means.

The error term is Mean Square(Error) = 184.500.

- a. Uses Harmonic Mean Sample Size = 60.000.
c. Alpha = .05.

1.1.5.2 F₀

Tests of Between-Subjects Effects

Dependent Variable: F₀

Source	Type III Sum of Squares	df	Mean Square	F	Sig.
Corrected Model	191713.737 ^a	11	17428.522	271.091	.000
Intercept	8149686.780	1	8149686.780	126763.918	.000
Treatment	61016.104	3	20338.701	316.357	.000
Time	96756.763	2	48378.382	752.499	.000
Treatment *Time	33940.869	6	5656.812	87.989	.000
Error	10800.766	168	64.290		
Total	8352201.283	180			
Corrected Total	202514.503	179			

- a. R Squared = .947 (Adjusted R Squared = .943)

F₀

Tukey HSD^{a,b}

Treatment	N	Subset	
		1	2
Control	45	181.0376	
10 degree C	45		221.9038
20 degree C	45		221.9556
5 degree C	45		226.2298
Sig.		1.000	.055

Means for groups in homogeneous subsets are displayed.

Based on observed means.

The error term is Mean Square(Error) = 64.290.

- a. Uses Harmonic Mean Sample Size = 45.000.
b. Alpha = .05.

F_0 Tukey HSD^{a,b}

Time	N	Subset		
		1	2	3
9th day	60	187.3443		
6th day	60		207.5835	
day 0	60			243.4172
Sig.		1.000	1.000	1.000

Means for groups in homogeneous subsets are displayed.

Based on observed means.

The error term is Mean Square(Error) = 64.290.

a. Uses Harmonic Mean Sample Size = 60.000.

b. Alpha = .05.

1.1.5.3 F_v/F_m

Tests of Between-Subjects Effects

Dependent Variable: F_v/F_m

Source	Type III Sum of Squares	df	Mean Square	F	Sig.
Corrected Model	1.270 ^a	11	.115	664.619	.000
Intercept	53.432	1	53.432	307556.301	.000
Treatment	.074	3	.025	141.986	.000
Time	1.157	2	.579	3329.944	.000
Treatment *Time	.039	6	.007	37.494	.000
Error	.029	168	.000		
Total	54.731	180			
Corrected Total	1.299	179			

a. R Squared = .978 (Adjusted R Squared = .976)

 F_v/F_m Tukey HSD^{a,b}

Treatment	N	Subset	
		1	2
Control	45	.5098	
20 degree C	45		.5551
5 degree C	45		.5560
10 degree C	45		.5584
Sig.		1.000	.628

Means for groups in homogeneous subsets are displayed.

Based on observed means.

The error term is Mean Square (Error) = .000.

- a. Uses Harmonic Mean Sample Size = 45.000.
- b. Alpha = .05.

1.1.6 Disease severity

Tests of Between-Subjects Effects

Dependent Variable: Disease

Source	Type III Sum of Squares	df	Mean Square	F	Sig.
Corrected Model	272.865 ^a	47	5.806	25.826	.000
Intercept	2057.068	1	2057.068	9150.594	.000
Treatment	2.238	3	.746	3.318	.020
Time	264.011	2	132.006	587.209	.000
Cultivar	3.982	3	1.327	5.904	.001
Treatment * Time	1.067	6	.178	.791	.577
Treatment * Cultivar	.157	9	.017	.078	1.000
Time * Cultivar	1.056	6	.176	.783	.584
Treatment * Time *	.356	18	.020	.088	1.000
Cultivar					
Error	151.067	672	.225		
Total	2481.000	720			
Corrected Total	423.932	719			

a. R Squared = .644 (Adjusted R Squared = .619)

Disease

Tukey HSD^{a,b}

Treatment	N	Subset	
		1	2
5 degree C	180	1.6222	
10 degree C	180	1.6611	1.6611
20 degree C	180	1.7056	1.7056
Control	180		1.7722
Sig.		.342	.118

Means for groups in homogeneous subsets are displayed.

Based on observed means.

The error term is Mean Square (Error) = .225.

- a. Uses Harmonic Mean Sample Size = 180.000.
 b. Alpha = .05.

Disease

Tukey HSD^{a,b}

Time	N	Subset		
		1	2	3
3th day	240	1.0208		
6th day	240		1.5625	
9th day	240			2.4875
Sig.		1.000	1.000	1.000

Means for groups in homogeneous subsets are displayed.

Based on observed means.

The error term is Mean Square(Error) = .225.

- a. Uses Harmonic Mean Sample Size = 240.000.
 b. Alpha = .05.

Disease

Tukey HSD^{a,b}

Cultivar	N	Subset		
		1	2	3
Donatello	180	1.6111		
Lillo	180	1.6222	1.6222	
Celestial	180		1.7500	1.7500
Centro	180			1.7778
Sig.		.996	.053	.945

Means for groups in homogeneous subsets are displayed.

Based on observed means.

The error term is Mean Square(Error) = .225.

- a. Uses Harmonic Mean Sample Size = 180.000.
 b. Alpha = .05.

1.2 Lillo, Celestial, and Donatello

Lillo, Celestial, and Donatello had the same statistical results.

2. Experiment 1.2: Application of 1-MCP at different treatment days after harvest

2.1 Ethylene production

Tests of Between-Subjects Effects

Dependent Variable: Ethylene

Source	Type III Sum of Squares	df	Mean Square	F	Sig.
Corrected Model	3082.884 ^a	47	65.593	54.093	.000
Intercept	77960.710	1	77960.710	64292.411	.000
Treatment	408.639	3	136.213	112.332	.000
Time	2299.814	2	1149.907	948.302	.000
Cultivar	95.278	3	31.759	26.191	.000
Treatment * Time	209.218	6	34.870	28.756	.000
Treatment * Cultivar	9.146	9	1.016	.838	.583
Time * Cultivar	48.709	6	8.118	6.695	.000
Treatment * Time *	12.079	18	.671	.553	.924
Cultivar					
Error	116.409	96	1.213		
Total	81160.002	144			
Corrected Total	3199.293	143			

a. R Squared = .964 (Adjusted R Squared = .946)

Ethylene

Tukey HSD^{a,b}

Treatment	N	Subset	
		1	2
1st	36	21.4229	
3rd	36	21.7721	
5th	36		24.6832
Control	36		25.1932
Sig.		.537	.209

Means for groups in homogeneous subsets are displayed.

Based on observed means.

The error term is Mean Square(Error) = 1.213.

a. Uses Harmonic Mean Sample Size = 36.000.

EthyleneTukey HSD^{a,b}

Time	N	Subset		
		1	2	3
10th day	48	18.9479		
7th day	48		22.2719	
day 0	48			28.5838
Sig.		1.000	1.000	1.000

Means for groups in homogeneous subsets are displayed.

Based on observed means.

The error term is Mean Square(Error) = 1.213.

a. Uses Harmonic Mean Sample Size = 48.000.

b. Alpha = .05.

EthyleneTukey HSD^{a,b}

Cultivar	N	Subset		
		1	2	3
Donatello	36	22.3113		
Lillo	36		23.0900	
Centro	36		23.1083	
Celestial	36			24.5619
Sig.		1.000	1.000	1.000

Means for groups in homogeneous subsets are displayed.

Based on observed means.

The error term is Mean Square(Error) = 1.213.

a. Uses Harmonic Mean Sample Size = 36.000.

c. Alpha = .05.

2.2 Disease severity

Tests of Between-Subjects Effects

Dependent Variable: Disease

Source	Type III Sum of Squares	df	Mean Square	F	Sig.
Corrected Model	276.128 ^a	47	5.875	26.967	.000
Intercept	2033.472	1	2033.472	9333.971	.000
Cultivar	3.472	3	1.157	5.313	.001
Treatment	1.828	3	.609	2.797	.039
Time	267.569	2	133.785	614.094	.000
Cultivar * Treatment	.161	9	.018	.082	1.000
Cultivar * Time	1.753	6	.292	1.341	.237
Treatment * Time	1.131	6	.188	.865	.520
Cultivar * Treatment * Time	.214	18	.012	.055	1.000
Error	146.400	672	.218		
Total	2456.000	720			
Corrected Total	422.528	719			

a. R Squared = .654 (Adjusted R Squared = .629)

Disease

Tukey HSD^{a,b}

Cultivar	N	Subset	
		1	2
Donatello	180	1.6111	
Lillo	180	1.6111	
Celestial	180		1.7500
Centro	180		1.7500
Sig.		1.000	1.000

Disease

Tukey HSD^{a,b}

Treatment	N	Subset	
		1	2
1st day	180	1.6167	
3rd day	180	1.6611	1.6611
5th day	180	1.6889	1.6889
Control	180		1.7556
Sig.		.458	.221

Means for groups in homogeneous subsets are displayed.

Based on observed means.

The error term is Mean Square(Error) = .218.

a. Uses Harmonic Mean Sample Size = 180.000.

b. Alpha = .05.

DiseaseTukey HSD^{a,b}

Time	N	Subset		
		1	2	3
4th day	240	1.0000		
7th day	240		1.5625	
10th day	240			2.4792
Sig.		1.000	1.000	1.000

Means for groups in homogeneous subsets are displayed.

Based on observed means.

The error term is Mean Square(Error) = .218.

a. Uses Harmonic Mean Sample Size = 240.000.

d. Alpha = .05.

2.3 CO₂ production, acoustic firmness, hue angle value, and chlorophyll fluorescence parameters

CO₂ production, acoustic firmness, hue angle value, and chlorophyll fluorescence parameters of 4 cultivars had the same statistical results to ethylene production.

3. Experiment 1.3: Comparison of conventional 1-MCP and 1-MCP microbubbles (MBs)

3.1 Ethylene production

Tests of Between-Subjects Effects

Dependent Variable: Ethylene

Source	Type III Sum of Squares	df	Mean Square	F	Sig.
Corrected Model	377.904 ^a	19	19.890	9.820	.000
Intercept	55580.334	1	55580.334	27441.219	.000
Treatment	.000	0	.	.	.
Treat period	73.634	2	36.817	18.177	.000
Time	122.153	3	40.718	20.103	.000
Treatment * Treat period	.000	0	.	.	.
Treatment * Time	.000	0	.	.	.
Treat period * Time	38.338	6	6.390	3.155	.013
Treatment * Treat period * Time	.000	0	.	.	.
Error	81.017	40	2.025		
Total	59237.442	60			
Corrected Total	458.922	59			

a. R Squared = .823 (Adjusted R Squared = .740)

Ethylene

Tukey HSD^{a,b,c}

Treatment	N	Subset	
		1	2
Gas	12	30.0383	
MBs	36	30.8812	
Control	12		33.8143
Sig.		.239	1.000

Means for groups in homogeneous subsets are displayed.

Based on observed means.

The error term is Mean Square(Error) = 2.025.

a. Uses Harmonic Mean Sample Size = 15.429.

b. The group sizes are unequal. The harmonic mean of the group sizes is used. Type I error levels are not guaranteed.

c. Alpha = .05.

EthyleneTukey HSD^{a,b}

Treatperiod	N	Subset	
		1	2
MBs-45 min	12	29.8350	
MBs-30 min	12	29.9052	
Gas-1440 min	12	30.0383	
MBs-15 min	12		32.9033
Control	12		33.8143
Sig.		.997	.526

Means for groups in homogeneous subsets are displayed.

Based on observed means.

The error term is Mean Square(Error) = 2.025.

a. Uses Harmonic Mean Sample Size = 12.000.

b. Alpha = .05.

EthyleneTukey HSD^{a,b}

Time	N	Subset	
		1	2
day 0	15	29.4300	
9th day	15	30.5313	
6th day	15		32.3743
3rd day	15		32.8613
Sig.		.164	.785

Means for groups in homogeneous subsets are displayed.

Based on observed means.

The error term is Mean Square(Error) = 2.025.

a. Uses Harmonic Mean Sample Size = 15.000.

b. Alpha = .05.

3.2 CO₂ production, acoustic firmness, hue angle value, and chlorophyll fluorescence parameters

CO₂ production, acoustic firmness, hue angle value, and chlorophyll fluorescence parameters had the same statistical results to ethylene production.

4. Experiment 2: Effect of conventional 1-MCP, ethylene absorber and ozone treatment

4.1 Ethylene production

Tests of Between-Subjects Effects

Dependent Variable: Ethylene

Source	Type III Sum of Squares	df	Mean Square	F	Sig.
Corrected Model	1335.142 ^a	17	78.538	33.235	.000
Intercept	33834.037	1	33834.037	14317.628	.000
Treatment	371.306	5	74.261	31.425	.000
Time	770.757	2	385.379	163.082	.000
Treatment * Time	193.078	10	19.308	8.171	.000
Error	85.072	36	2.363		
Total	35254.250	54			
Corrected Total	1420.213	53			

a. R Squared = .940 (Adjusted R Squared = .912)

Ethylene

Tukey HSD^{a,b}

Treatment	N	Subset	
		1	2
1-MCP	9	22.2773	
1-MCP EA	9	22.3562	
1-MCP Ozone	9	22.6068	
EA	9		27.4494
Ozone	9		27.6373
Control	9		27.8596
Sig.		.997	.993

Means for groups in homogeneous subsets are displayed.

Based on observed means.

The error term is Mean Square(Error) = 2.363.

a. Uses Harmonic Mean Sample Size = 9.000.

a. Alpha = .05.

EthyleneTukey HSD^{a,b}

Time	N	Subset		
		1	2	3
14th day	18	20.9936		
10th day	18		24.0194	
day 0	18			30.0803
Sig.		1.000	1.000	1.000

Means for groups in homogeneous subsets are displayed.

Based on observed means.

The error term is Mean Square(Error) = 2.363.

a. Uses Harmonic Mean Sample Size = 18.000.

b. Alpha = .05.

4.2 Chilling injury**Tests of Between-Subjects Effects**

Dependent Variable: Chilling injury

Source	Type III Sum of Squares	df	Mean Square	F	Sig.
Corrected Model	15.689 ^a	23	.682	4.897	.000
Intercept	1655.511	1	1655.511	11885.721	.000
Treat	7.689	5	1.538	11.040	.000
Time	6.600	3	2.200	15.795	.000
Treat * Time	1.400	15	.093	.670	.814
Error	46.800	336	.139		
Total	1718.000	360			
Corrected Total	62.489	359			

a. R Squared = .251 (Adjusted R Squared = .200)

Chilling injuryTukey HSD^{a,b}

Treat	N	Subset	
		1	2
1-MCP + EA	60	2.0167	
EA	60	2.0333	
1-MCP	60	2.0500	
Control	60	2.0667	
Ozone	60		2.3500
1-MCP + Ozone	60		2.3500
Sig.		.978	1.000

Means for groups in homogeneous subsets are displayed.

Based on observed means.

The error term is Mean Square(Error) = .139.

a. Uses Harmonic Mean Sample Size = 60.000.

b. Alpha = .05.

Chilling injury

Tukey HSD^{a,b}

Time	N	Subset	
		1	2
4th day	90	1.9111	
8th day	90		2.2000
10th day	90		2.2333
14th day	90		2.2333
Sig.		1.000	.932

Means for groups in homogeneous subsets are displayed.

Based on observed means.

The error term is Mean Square(Error) = .139.

a. Uses Harmonic Mean Sample Size = 90.000.

e. Alpha = .05.

4.3 Disease severity

Tests of Between-Subjects Effects

Dependent Variable: Disease

Source	Type III Sum of Squares	df	Mean Square	F	Sig.
Corrected Model	119.424 ^a	29	4.118	29.150	.000
Intercept	930.242	1	930.242	6584.861	.000
Treatment	6.278	5	1.256	8.888	.000
Time	101.924	4	25.481	180.372	.000
Treatment * Time	11.222	20	.561	3.972	.000
Error	59.333	420	.141		
Total	1109.000	450			
Corrected Total	178.758	449			

a. R Squared = .668 (Adjusted R Squared = .645)

DiseaseTukey HSD^{a,b}

Treatment	N	Subset		
		1	2	3
1-MCP	75	1.2667		
1-MCP + EA	75	1.3200	1.3200	
1-MCP + Ozone	75	1.4400	1.4400	
Ozone	75		1.4800	1.4800
EA	75		1.4933	1.4933
Control	75			1.6267
Sig.		.056	.056	.162

Means for groups in homogeneous subsets are displayed.

Based on observed means.

The error term is Mean Square(Error) = .141.

a. Uses Harmonic Mean Sample Size = 75.000.

b. Alpha = .05.

DiseaseTukey HSD^{a,b}

Time	N	Subset			
		1	2	3	4
4th day	90	1.0000			
8th day	90	1.1222	1.1222		
10th day	90		1.1889		
12th day	90			1.5667	
14th day	90				2.3111
Sig.		.189	.757	1.000	1.000

Means for groups in homogeneous subsets are displayed.

Based on observed means.

The error term is Mean Square(Error) = .141.

a. Uses Harmonic Mean Sample Size = 90.000.

b. Alpha = .05.

4.4 CO₂ production, acoustic firmness, hue angle value, and chlorophyll fluorescence parameters

CO₂ production, acoustic firmness, hue angle value, and chlorophyll fluorescence parameters had the same statistical results to ethylene production.

5. Experiment 3: Effect of washing treatment

5.1 Mesophilic aerobes populations

5.1.1 Mesophilic aerobes after treatment

Tests of Between-Subjects Effects

Dependent Variable: mesophilic aerobes after treatment

Source	Type III Sum of Squares	df	Mean Square	F	Sig.
Corrected Model	14.415 ^a	11	1.310	960.592	.000
Intercept	243.430	1	243.430	178445.073	.000
Treatment	14.415	11	1.310	960.592	.000
Error	.033	24	.001		
Total	257.877	36			
Corrected Total	14.447	35			

a. R Squared = .998 (Adjusted R Squared = .997)

Mesophilic aerobes after treatment

Tukey HSD^{a,b}

Treatment	N	Subset						
		1	2	3	4	5	6	7
Ozone MB 5 min	3	1.4519						
Hot water+ MB 2 min	3		1.7438					
Hot water+ MB 5 min	3			1.9749				
Ozone MB 2 min	3				2.5104			
Hot water 2 min	3					2.6220		
Chlorine 2 min	3					2.6864	2.6864	
Hot water 5 min	3					2.6963	2.6963	
Chlorine + MB 5 min	3					2.7208	2.7208	
Chlorine + MB 2 min	3					2.7229	2.7229	
Chlorine 5 min	3						2.7371	
Tap water	3							3.6251
Control	3							3.7129
Sig.		1.000	1.000	1.000	1.000	.087	.861	.198

Means for groups in homogeneous subsets are displayed.

Based on observed means.

The error term is Mean Square(Error) = .001.

a. Uses Harmonic Mean Sample Size = 3.000.

b. Alpha = .05.

5.1.1 Mesophilic aerobes after 4 days of shelf-life

Tests of Between-Subjects Effects

Dependent Variable: mesophilic aerobes - 4th day of shelf-life

Source	Type III Sum of Squares	df	Mean Square	F	Sig.
Corrected Model	64.710 ^a	11	5.883	1533123.000	.000
Intercept	1216.998	1	1216.998	317167253.335	.000
Treatment	64.710	11	5.883	1533123.000	.000
Error	9.209E-5	24	3.837E-6		
Total	1281.708	36			
Corrected Total	64.710	35			

Mesophilic aerobes- 4th day of shelf-life

Tukey HSD^{a,b}

Treatment	N	Subset											
		1	2	3	4	5	6	7	8	9	10	11	12
Hot water+ MB 2 min	3	2.934											
Ozone MB 5 min	3		4.179										
Hot water+ MB 5 min	3			4.534									
Chlorine 2 min	3				5.359								
Chlorine 5 min	3					5.595							
Chlorine + MB 2 min	3						5.748						
Chlorine + MB 5 min	3							6.131					
Hot water 5 min	3								6.591				
Ozone MB 2 min	3									6.630			
Hot water 2 min	3										6.985		
Tap water	3											7.536	
Control	3												7.546
Sig.		1.000	1.000	1.000	1.000	1.000	1.000	1.000	1.000	1.000	1.000	1.000	1.000

Means for groups in homogeneous subsets are displayed.

Based on observed means.

The error term is Mean Square(Error) = 3.84E-006.

a. Uses Harmonic Mean Sample Size = 3.000.

b. Alpha = .05.

5.2 Disease severity

Tests of Between-Subjects Effects

Dependent Variable: Disease

Source	Type III Sum of Squares	df	Mean Square	F	Sig.
Corrected Model	16.025 ^a	11	1.457	3.943	.000
Intercept	621.075	1	621.075	1681.105	.000
Treatment	16.025	11	1.457	3.943	.000
Error	39.900	108	.369		
Total	677.000	120			
Corrected Total	55.925	119			

a. R Squared = .287 (Adjusted R Squared = .214)

Disease

Tukey HSD^{a,b}

Treatment	N	Subset		
		1	2	3
HW MB 2min	10	1.6000		
HW MB 5min	10	1.7000		
Oz MB 5min	10	1.8000	1.8000	
Chlorine 5min	10	2.3000	2.3000	2.3000
HW 2min	10	2.3000	2.3000	2.3000
HW 5min	10	2.3000	2.3000	2.3000
Chlorine MB 5min	10	2.4000	2.4000	2.4000
Oz MB 2min	10	2.4000	2.4000	2.4000
Chlorine 2min	10	2.5000	2.5000	2.5000
Chlorine MB 2min	10	2.5000	2.5000	2.5000
Tap water	10		2.7000	2.7000
Control	10			2.8000
Sig.		.054	.054	.793

Means for groups in homogeneous subsets are displayed.

Based on observed means.

The error term is Mean Square(Error) = .369.

a. Uses Harmonic Mean Sample Size = 10.000.

b. Alpha = .05.